



PARTS CATALOGUE

YZ250'07 (1P8C) SOUTH AFRICA

YZ250W1
YZ250W/YZ250
PARTS CATALOGUE
©2006 by Yamaha Motor Co., Ltd.
1st edition, June 2006
All rights reserved.
Any reprinting or unauthorized use
without the written permission of
Yamaha Motor Co., Ltd.
is expressly prohibited.

A3



A4

FOREWORD

This Parts Catalogue is related to the parts for the model(s) on the cover page. When you are ordering replacement parts, please refer to this Parts Catalogue and quote both part numbers and part names correctly.

1. Modifications or additions which have been made after the issue of the Parts Catalogue will be announced in the Parts News.

It is advisable that you make the necessary corrections to the Parts Catalogue according to the Parts News.

2. Abbreviations

The following abbreviations are used in this Parts Catalogue.

“UR” Use specified parts number.

“UN” Use as many as needed.

“AP” Alternate Parts

“LM” Locally Made (Parts need to be ordered locally)

“F#” Frame No. (Applicable machine No.)

“O/S” Over Size

3. The number of components for assembly

- Parts, which are to be supplied in an assembly, are listed with a dot (.) in front of the part name as shown below.
- The numeral appearing to the right of each component part indicates the quantity of parts for each assembly unit.

PART NO.	DESCRIPTION	Q'TY	REMARKS
2F5-83310-60	FRONT FLASHER LIGHT ASSY	2	
115-83311-60	.BULB (6V-18W)	1	

4. Applicable colours of graphics are represented in the “REMARKS” as shown below.

PART NO.	DESCRIPTION	Q'TY	REMARKS
2N4-24110-00-X5	FUEL TANK COMP.	2	MXR
3J1-24240-10	.GRAPHIC, FUEL TANK	1	FOR MXR

5. Note that the illustrations for reference in finding parts numbers are not to be used for assembling. When assembling, please use the applicable service manual.

6. The asterisk (*) before a reference number indicates modified items after the first edition.

FOREWORD

7. Applicable Serial No.

Engine Serial No.

Frame Serial No.

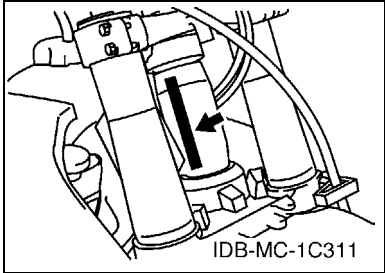
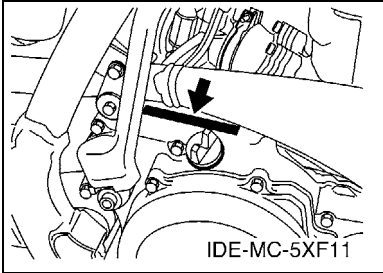

8. Applicable Colour Code (The (*) mark shows Model colour.)

Abbreviation	Colour Name	Colour Code
DPBSE(*)	DEEP PURPLISH BLUE SOLID E	0583

MODEL LABEL

(1) A label called "Model Label" is affixed in the location as indicated in (3) below.
When using this parts catalogue, please be sure to cross-reference the "model code – production code No." in the catalogue with the "model code – production code No." indicated on the Model Label affixed onto the product concerned.

(2) "Model Label" Indication

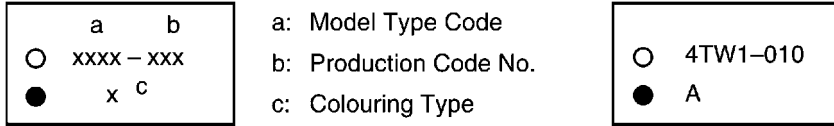

(3) Model Label Affixing Location

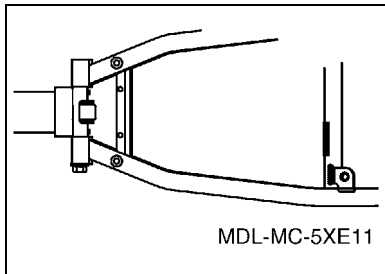

(4) Colouring Information

Model Code	Colouring Type Code	Colour Code	Colour Name	Abbreviation
1P89	A	0583	DEEP PURPLISH BLUE SOLID E	DPBSE
1P8A	A	0583	DEEP PURPLISH BLUE SOLID E	DPBSE
1P8B	A	0583	DEEP PURPLISH BLUE SOLID E	DPBSE
1P8C	A	0583	DEEP PURPLISH BLUE SOLID E	DPBSE

(5) Model Code – Production Code Number of Model Listed in This Parts Catalogue

Model Code	Production Code No.	Country (destination)	Model Code	Production Code No.	Country (destination)
1P89	010	U.S.A.			
	020	CANADA			
1P8A	010	EUROPE			
1P8B	010	JAPAN			
1P8C	010	AUSTRALIA			
		NEW ZEALAND			
	020	SOUTH AFRICA			

CONTENTS

ENGINE

CYLINDER HEAD	B2
GOVERNOR	B4
CRANKSHAFT & PISTON	B5
WATER PUMP	B6
RADIATOR & HOSE	B7
INTAKE	B8
CARBURETOR	B9
EXHAUST	B12
CRANKCASE	B14
CRANKCASE COVER 1	B15
STARTER	C2
CLUTCH	C3
TRANSMISSION	C5
SHIFT CAM & FORK	C7
SHIFT SHAFT	C8

CHASSIS

FRAME	C9
FENDER	C11
SIDE COVER	C13
REAR ARM	C14
REAR SUSPENSION	D2
STEERING	D4
FRONT FORK	D5
FUEL TANK	D8
SEAT	D10
FRONT WHEEL	D11
FRONT BRAKE CALIPER	D12
REAR WHEEL	D13
REAR BRAKE CALIPER	D15
STEERING HANDLE & CABLE	E2
FRONT MASTER CYLINDER	E3
STAND & FOOTREST	E4
REAR MASTER CYLINDER	E5
GENERATOR	E6
HANDLE SWITCH & LEVER	E7
ELECTRICAL 1	E8
ALTERNATE FOR CHASSIS	E9
OPTIONAL PARTS 1	E10

INDEX

NUMERICAL INDEX	M1
-----------------------	----

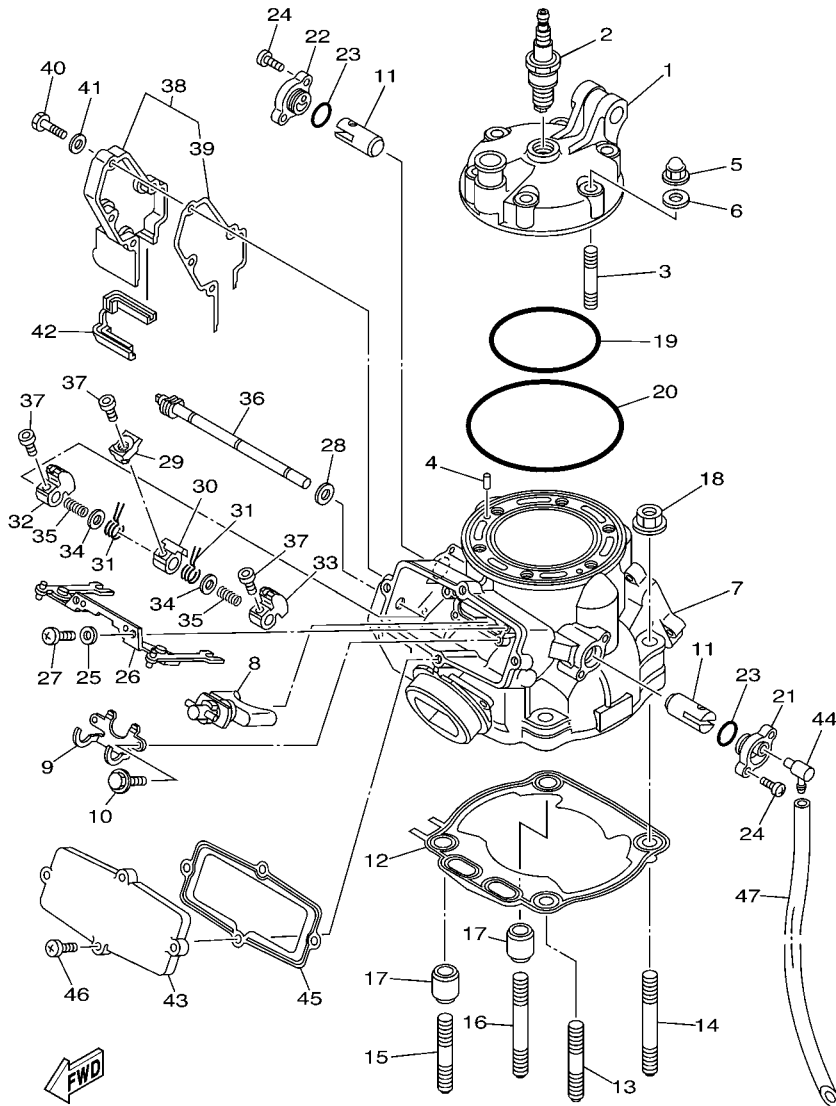

5NX1100-A010

FIG. 1 CYLINDER HEAD

REF. NO.	PART NO.	DESCRIPTION	1P89	1P8A	1P8B	1P8C	REMARKS
1	5MW-11111-01	HEAD, CYLINDER 1				1	
2	94702-00326	PLUG, SPARK (NGK BR8EG)	1	1		1	
3	90116-08027	BOLT, STUD	6	6	6	6	
4	93604-08071	PIN, DOWEL	2	2	2	2	
5	90176-08005	NUT, CROWN	6	6	6	6	
6	90201-080L8	WASHER, PLATE	6	6	6	6	
7	5UP-11311-10	CYLINDER 1	1	1	1	1	
8	5XF-1131D-00	VALVE ASSY	1	1	1	1	
9	5CU-1131U-10	HOLDER 3	1	1	1	1	
10	90109-05001	BOLT	2	2	2	2	
11	5CU-1132A-00	VALVE 2	2	2	2	2	
12	5UP-11351-00	GASKET, CYLINDER	1	1	1	1	
13	90116-10034	BOLT, STUD	1	1	1	1	
14	95612-10660	BOLT, STUD	1	1	1	1	
15	90116-10034	BOLT, STUD	1	1	1	1	
16	95612-10660	BOLT, STUD	1	1	1	1	
17	99590-14016	PIN, DOWEL	2	2	2	2	
18	90179-10M35	NUT	4	4	4	4	
19	93210-74316	O-RING	1	1	1	1	
20	93211-02703	O-RING	1	1	1	1	
21	5CU-1131E-01	HOLDER 1	1	1	1	1	
22	5CU-1131P-00	HOLDER 4	1	1	1	1	
23	93210-15639	O-RING	2	2	2	2	
24	98502-05012	SCREW, PAN HEAD	4	4	4	4	
25	90201-05021	WASHER, PLATE	2	2	2	2	

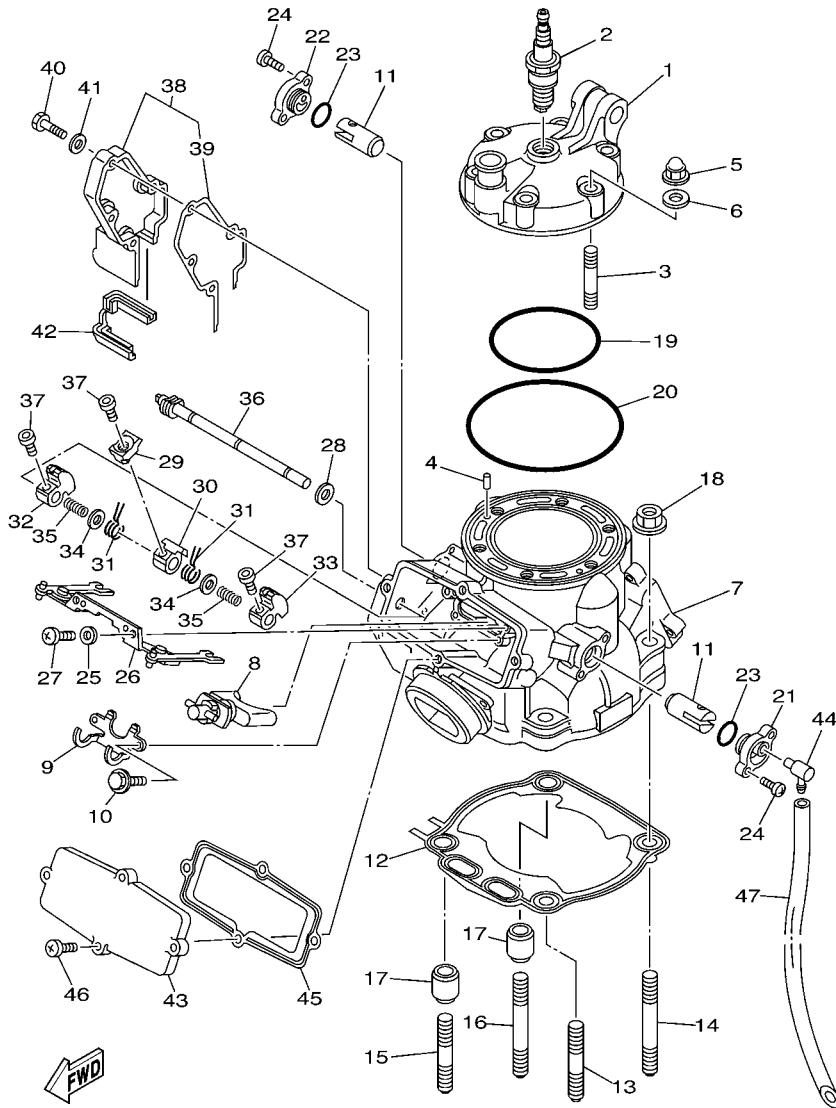

5NX1100-A010

FIG. 1 CYLINDER HEAD

REF. NO.	PART NO.	DESCRIPTION	1P89	1P8A	1P8B	1P8C	REMARKS
26	5CU-11830-00	LINK ASSY	1	1	1	1	
27	98902-05012	SCREW, BIND	2	2	2	2	
28	93104-08040	OIL SEAL	1	1	1	1	
29	5NX-11395-00	HOLDER	1	1	1	1	
30	4SS-11832-00	LEVER, LINK	1	1	1	1	
31	90508-155B8	SPRING, TORSION	2	2	2	2	
32	5MW-1132E-00	PULLEY 1	1	1	1	1	
33	5MW-1132F-00	PULLEY 2	1	1	1	1	
34	90201-081G0	WASHER, PLATE	2	2	2	2	
35	90501-046L6	SPRING, COMPRESSION	2	2	2	2	
36	5CU-1131V-00	SHAFT 1	1	1	1	1	
37	91312-04008	BOLT	3	3	3	3	
38	5CU-11991-00	HOUSING 1	1	1	1	1	
39	5CU-11993-00	.GASKET	1	1	1	1	
40	97002-05020	BOLT	4	4	4	4	
41	92902-05600	WASHER, PLATE	4	4	4	4	
42	5CU-11995-00	SEAL, HOUSING	1	1	1	1	
43	5CU-1131M-10	COVER	1	1	1	1	
44	353-13115-01	CONNECTOR, SUCTION PIPE	1	1	1	1	
45	5CU-11354-00	GASKET	1	1	1	1	
46	98902-05016	SCREW, BIND	4	4	4	4	
47	90445-09777	HOSE (L300)	1	1	1	1	

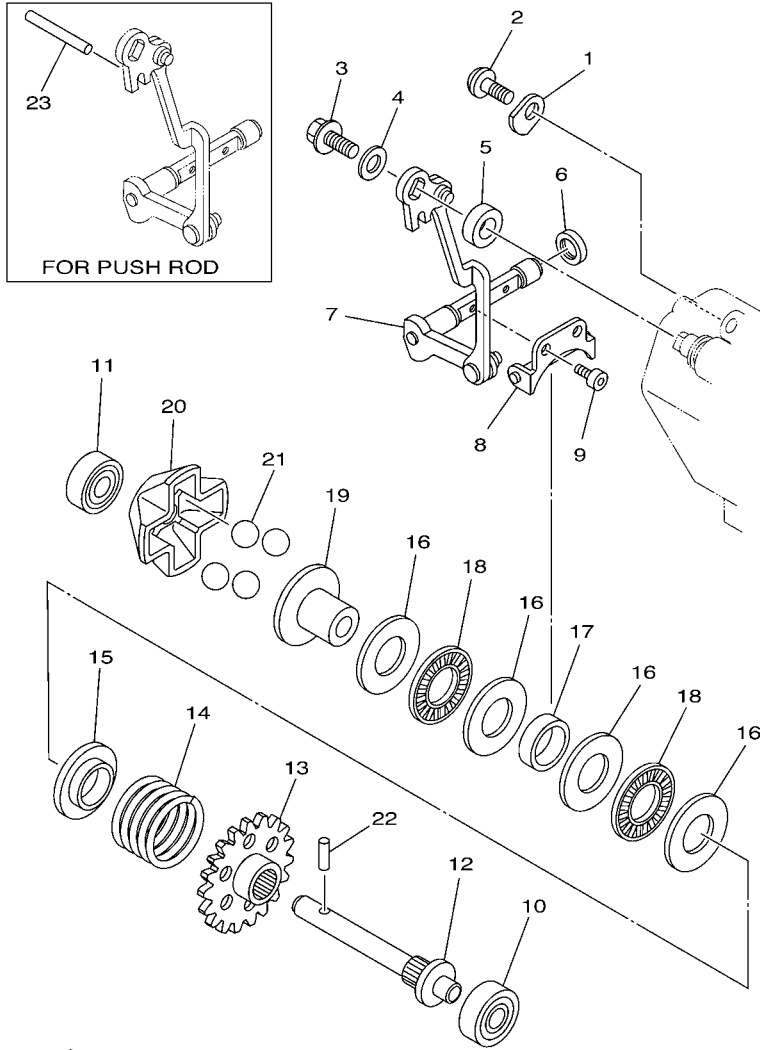

5NX1100-A020

FIG. 2 GOVERNOR

REF. NO.	PART NO.	DESCRIPTION	1P89	1P8A	1P8B	1P8C	REMARKS
1	4JY-11915-10	PLATE, THRUST 1	1	1	1	1	
2	98902-05012	SCREW, BIND	1	1	1	1	
3	90105-05014	BOLT, FLANGE	1	1	1	1	
4	90201-05021	WASHER, PLATE	1	1	1	1	
5	90387-085E1	COLLAR	1	1	1	1	
6	93104-08040	OIL SEAL	1	1	1	1	
7	5CU-11990-10	PUSH ROD ASSY	1	1	1	1	
8	3JE-11922-01	FORK, GOVERNOR	1	1	1	1	
9	91312-04006	BOLT	2	2	2	2	
10	93300-60801	BEARING	1	1	1	1	KOYO
11	93300-60801	BEARING	1	1	1	1	KOYO
12	5X4-11921-02	SHAFT, GOVERNOR	1	1	1	1	
13	5NY-11953-00	GEAR, GOVERNOR	1	1	1	1	
14	90501-256L2	SPRING, COMPRESSION	1	1	1	1	
15	5CU-11952-00	PLATE	1	1	1	1	
16	90201-150U6	WASHER, PLATE	4	4	4	4	
17	90387-152F2	COLLAR	1	1	1	1	
18	93340-21505	BEARING	2	2	2	2	
19	5CU-11912-00	RETAINER, WEIGHT	1	1	1	1	
20	5CU-11911-00	RETAINER	1	1	1	1	
21	93507-16020	BALL	4	4	4	4	
22	93603-14240	PIN, DOWEL	1	1	1	1	
23	93604-29184	PIN, DOWEL	1	1	1	1	AP

FIG. 3 CRANKSHAFT & PISTON

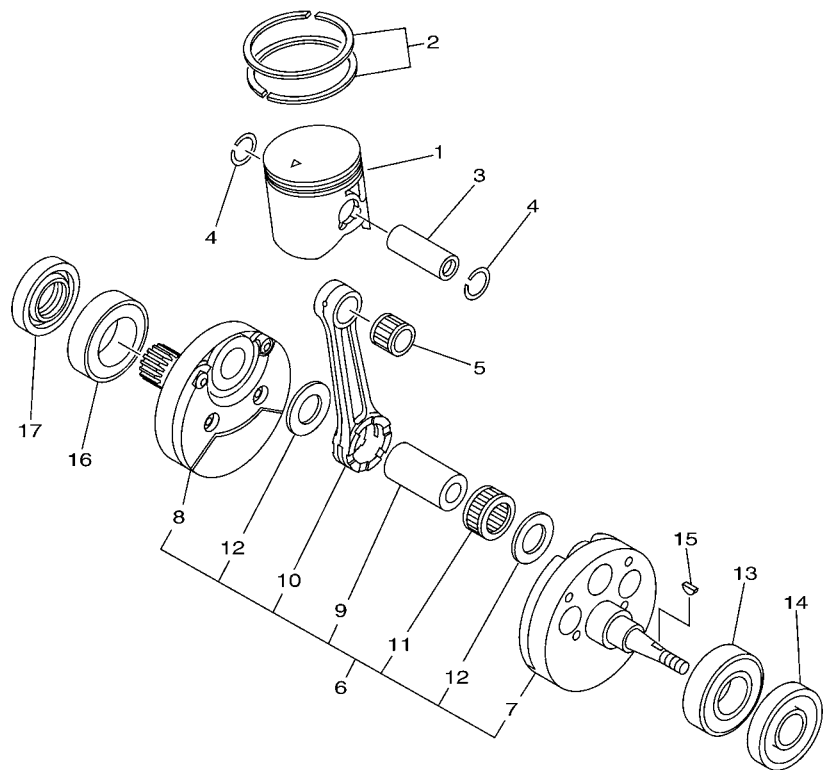

REF. NO.	PART NO.	DESCRIPTION	1P89	1P8A	1P8B	1P8C	REMARKS
1	1P8-11631-00-A0	PISTON (STD)	1	1	1	1	UR RED
	1P8-11631-00-B0	PISTON (STD)	1	1	1	1	UR ORANGE
	1P8-11631-00-C0	PISTON (STD)	1	1	1	1	UR GREEN
	1P8-11631-00-D0	PISTON (STD)	1	1	1	1	UR PURPLE
2	5CU-11603-10	PISTON RING SET (STD)	1	1	1	1	
3	5UP-11633-00	PIN, PISTON	1	1	1	1	
4	93450-19052	CIRCLIP	2	2	2	2	
5	93310-218A6	BEARING	1	1	1	1	
6	5UP-11400-10	CRANKSHAFT ASSY	1	1	1	1	
7	5UP-11410-10	.CRANKSHAFT	1	1	1	1	
8	5MW-11420-10	.CRANKSHAFT	1	1	1	1	
9	5CU-11681-00	.PIN, CRANK 1	1	1	1	1	
10	5MW-11651-00	.ROD, CONNECTING	1	1	1	1	
11	93310-52406	.BEARING	1	1	1	1	
12	90209-24327	.WASHER	2	2	2	2	
13	93306-37808	BEARING	1	1	1	1	
14	93102-20485	OIL SEAL	1	1	1	1	
15	90280-03017	KEY, WOODRUFF	1	1	1	1	
16	93306-37808	BEARING	1	1	1	1	
17	93102-28004	OIL SEAL	1	1	1	1	



5MW1100-1030

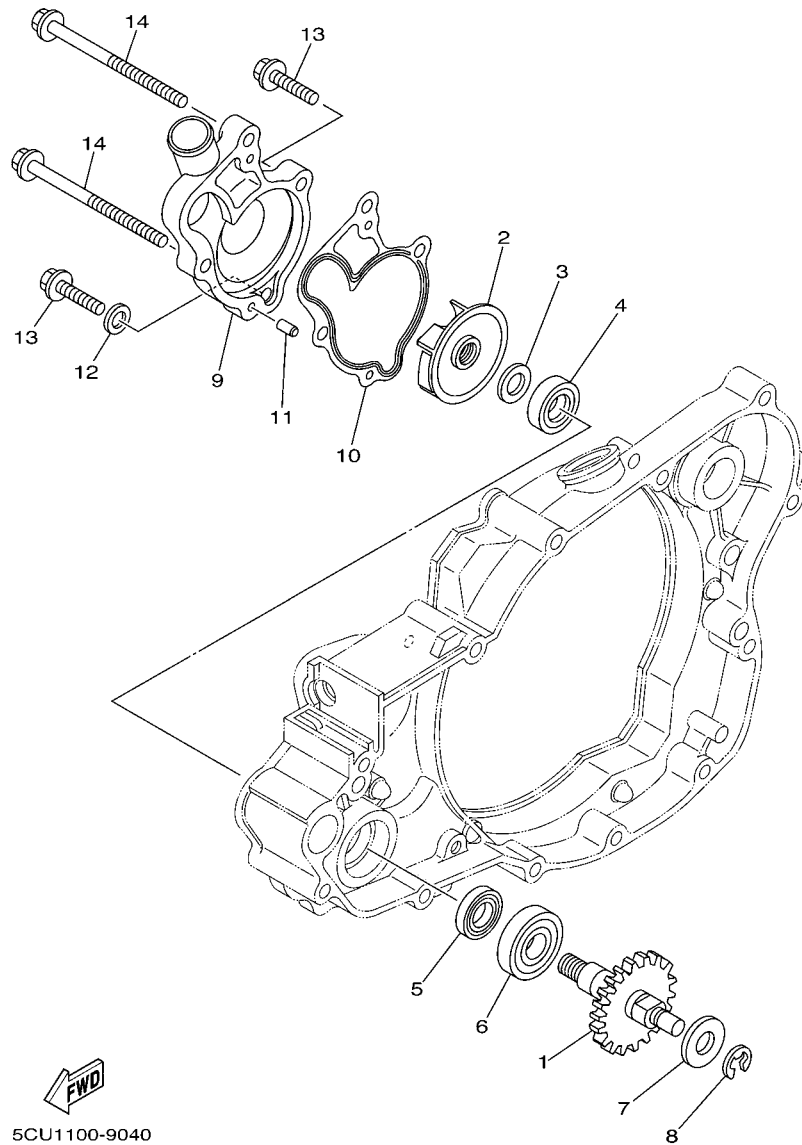
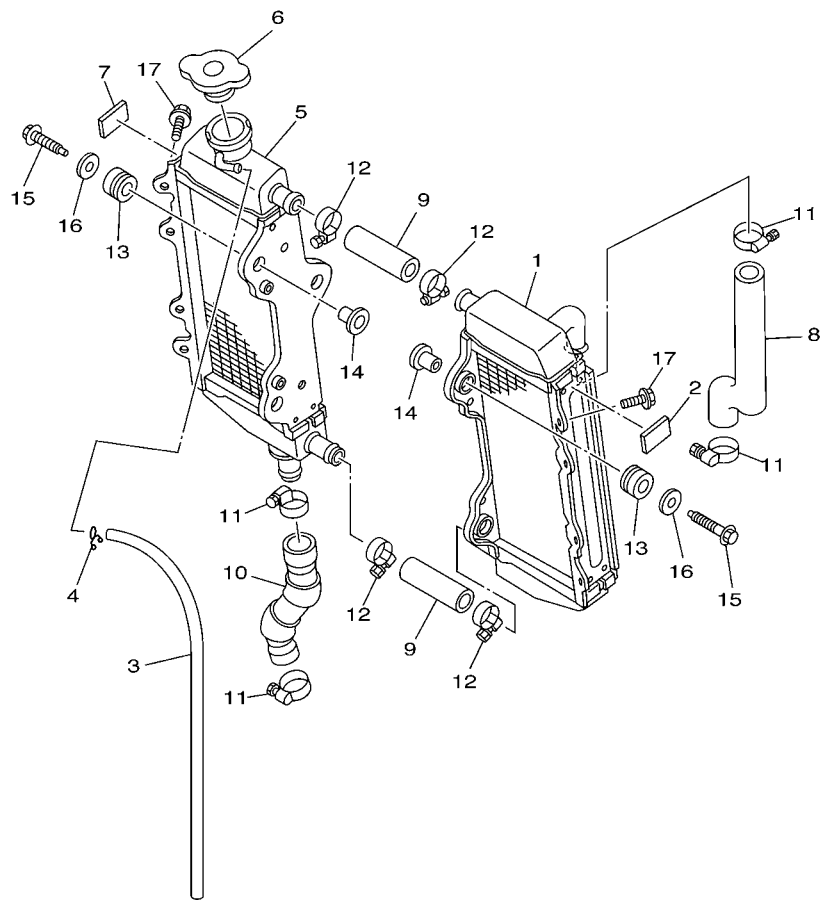

FIG. 4 WATER PUMP

REF. NO.	PART NO.	DESCRIPTION	1P89	1P8A	1P8B	1P8C	REMARKS
1	5CU-12459-00	GEAR, IMPELLER SHAFT	1	1	1	1	
2	5DJ-12451-00	IMPELLER, WATER PUMP	1	1	1	1	
3	90201-08512	WASHER, PLATE	1	1	1	1	
4	93109-11073	OIL SEAL	1	1	1	1	
5	93102-12106	OIL SEAL (SD 12-22-5 HS)	1	1	1	1	
6	93306-00105	BEARING	1	1	1	1	
7	90201-08784	WASHER, PLATE	1	1	1	1	
8	99001-06600	CIRCLIP	1	1	1	1	
9	5MW-12422-00	COVER, HOUSING	1	1	1	1	
10	5XF-12428-00	GASKET, HOUSING COVER 2	1	1	1	1	
11	93604-10011	PIN, DOWEL	2	2	2	2	
12	90430-06014	GASKET	1	1	1	1	
13	95022-06025	BOLT, FLANGE	2	2	2	2	
14	95022-06065	BOLT, FLANGE	2	2	2	2	

FIG. 5 RADIATOR & HOSE



1P81100-D050

REF. NO.	PART NO.	DESCRIPTION	1P89	1P8A	1P8B	1P8C	REMARKS
1	5NX-1240A-00	RADIATOR ASSY	1	1	1	1	
2	1C3-12465-00	DAMPER, RADIATOR	1	1	1	1	
3	91A20-05065	TUBE, FLEXIBLE VINYL	1	1	1	1	
4	90467-090A2	CLIP	1	1	1	1	
5	5NX-12461-00	RADIATOR ASSY	1	1	1	1	
6	22W-12462-00	CAP, RADIATOR	1	1	1	1	
7	1C3-12465-00	DAMPER, RADIATOR	1	1	1	1	
8	5CU-12481-10	PIPE 1	1	1	1	1	
9	5NY-12482-00	PIPE 2	2	2	2	2	
10	1P8-12484-00	PIPE 4	1	1	1	1	
11	90450-28001	HOSE CLAMP ASSY	4	4	4	4	
12	90450-25001	HOSE CLAMP ASSY	4	4	4	4	
13	90480-15528	GROMMET	6	6	6	6	
14	90387-06065	COLLAR	6	6	6	6	
15	90105-06111	BOLT, FLANGE	6	6	6	6	
16	90201-06571	WASHER, PLATE	6	6	6	6	
17	90105-06118	BOLT, FLANGE	2	2	2	2	

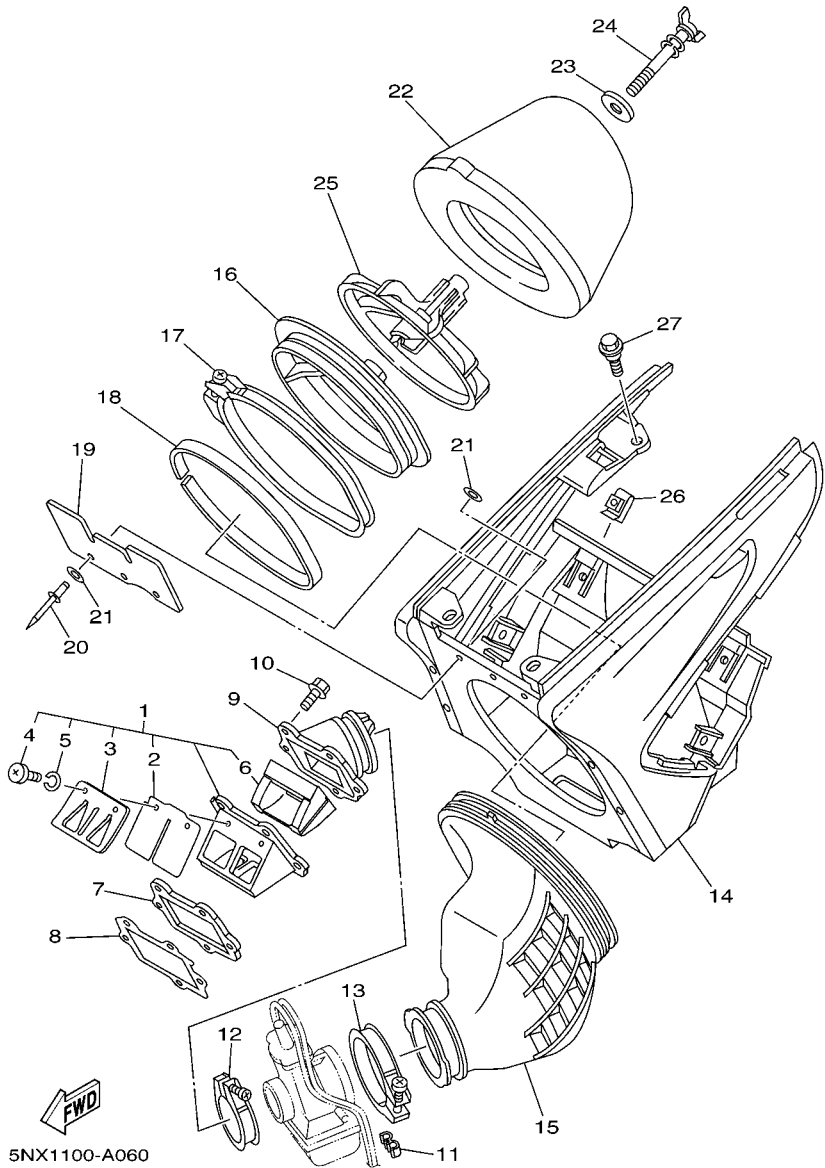

FIG. 6 INTAKE

REF. NO.	PART NO.	DESCRIPTION	1P89	1P8A	1P8B	1P8C	REMARKS
1	5NX-13610-10	REED VALVE ASSY	1	1	1	1	
2	5NX-13613-00	.REED, VALVE	2	2	2	2	
3	4XL-13616-10	.STOPPER, REED VALVE	2	2	2	2	
4	98502-03008	.SCREW, PAN HEAD	4	4	4	4	
5	92902-03100	.WASHER	4	4	4	4	
6	4XL-13625-00	.SPACER, REED VALVE	1	1	1	1	
7	5NX-13624-00	PLATE, REED VALVE	1	1	1	1	
8	5XF-13622-00	GASKET, VALVE SEAT	1	1	1	1	
9	5NX-13565-00	JOINT, CARBURETOR	1	1	1	1	
10	91312-06025	BOLT	5	5	5	5	
11	90464-06214	CLAMP	2	2	2	2	
12	90450-51001	HOSE CLAMP ASSY	1	1	1	1	
13	90450-70003	HOSE CLAMP ASSY	1	1	1	1	
14	5NY-14401-01	AIR CLEANER CASE ASSY	1	1	1	1	
15	5NX-14453-00	JOINT, AIR CLEANER 1	1	1	1	1	
16	5NY-14459-00	HOLDER, GUIDE	1	1	1	1	
17	5NY-14455-20	BAND	1	1	1	1	
18	5NY-14442-00	SPACER	1	1	1	1	
19	5NY-14417-00	COVER 1	1	1	1	1	
20	90267-32070	RIVET, BLIND	3	3	3	3	
21	90201-03313	WASHER, PLATE	6	6	6	6	
22	4XM-14451-00	ELEMENT, AIR CLEANER	1	1	1	1	
23	90209-06096	WASHER	1	1	1	1	
24	90122-06005	BOLT, WING	1	1	1	1	
25	3JD-14458-01	GUIDE	1	1	1	1	
26	90183-06023	NUT, SPRING	4	4	4	4	
27	90109-067F4	BOLT	4	4	4	4	

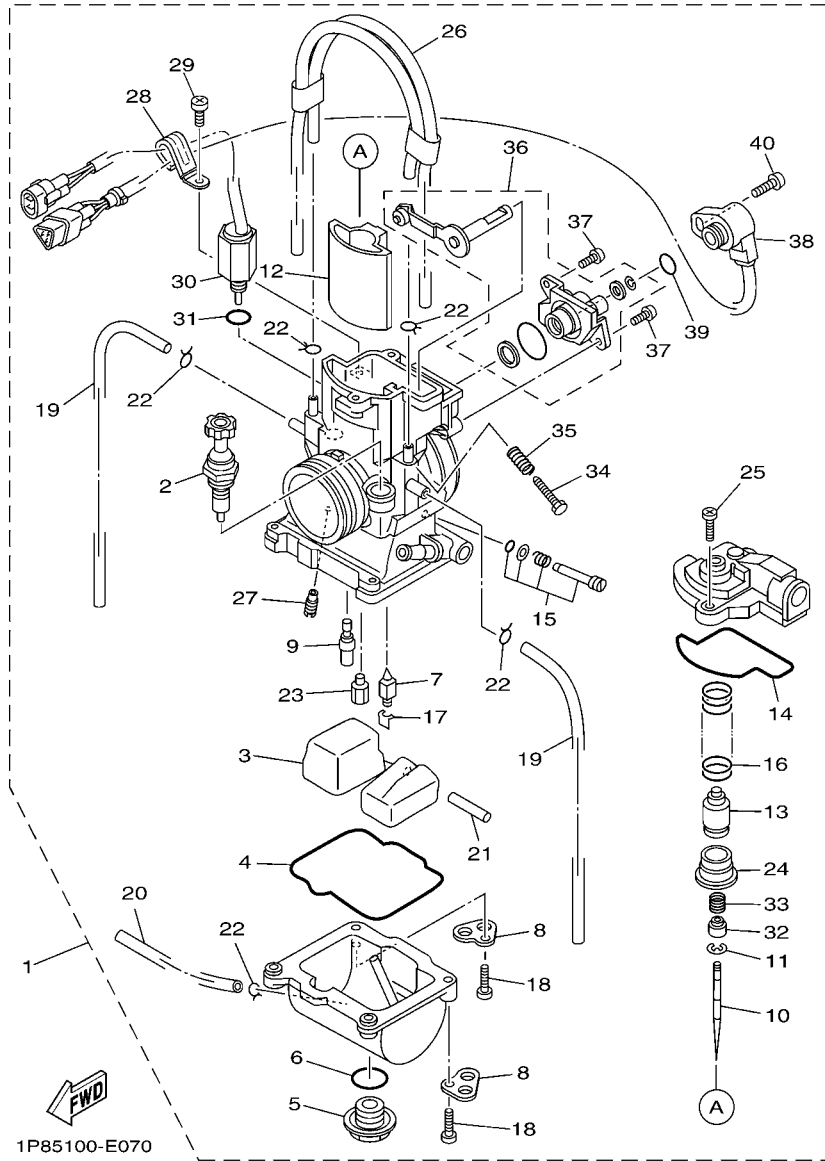
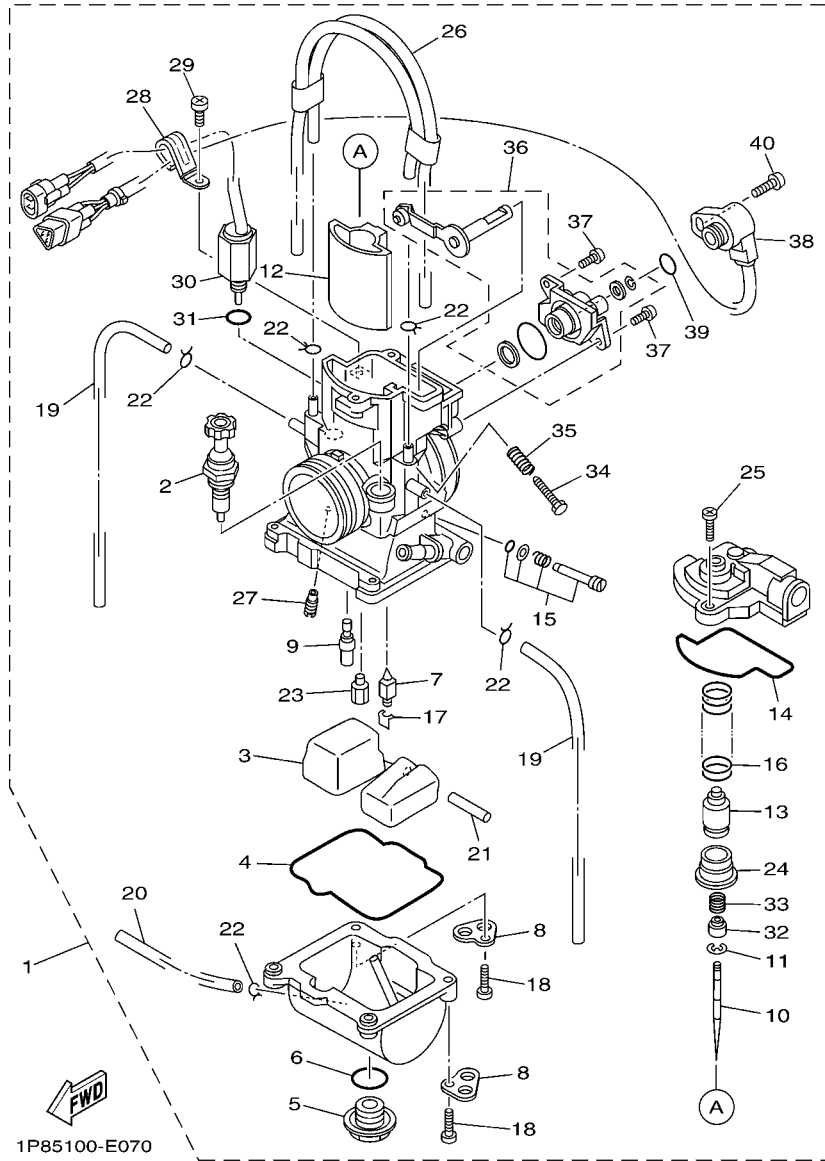

FIG. 7 CARBURETOR

REF. NO.	PART NO.	DESCRIPTION	1P89	1P8A	1P8B	1P8C	REMARKS
1	1P8-14101-50	CARBURETOR ASSY 1				1	
2	4JT-14171-00	.PLUNGER, STARTER	1	1	1	1	
3	4SR-14985-00	.FLOAT	1	1	1	1	
4	4JT-14984-00	.GASKET, FLOAT CHAMBER	1	1	1	1	
5	4MX-14115-00	.PLUG, SCREW	1	1	1	1	
6	4MX-14561-00	.O-RING	1	1	1	1	
7	4MX-14392-00	.VALVE, NEEDLE	1	1	1	1	
8	4XL-14146-00	.PLATE	2	2	2	2	
9	4MX-14948-07	.JET, SLOW (#50)	1		1	1	STD
	4MX-14948-02	.JET, SLOW (#38)	1	1	1	1	AP
	4MX-14948-03	.JET, SLOW (#40)	1	1	1	1	AP
	4MX-14948-04	.JET, SLOW (#42)	1	1	1	1	AP
	4MX-14948-05	.JET, SLOW (#45)	1	1	1	1	AP
	4MX-14948-06	.JET, SLOW (#48)	1	1	1	1	AP
	4MX-14948-08	.JET, SLOW (#52)	1		1	1	AP
	4MX-14948-09	.JET, SLOW (#55)	1	1	1	1	AP
	4MX-14948-10	.JET, SLOW (#58)	1	1	1	1	AP
	4MX-14948-11	.JET, SLOW (#60)	1	1	1	1	AP
	4MX-14948-12	.JET, SLOW (#62)	1	1	1	1	AP
10	4SR-14916-EW	.NEEDLE (N3EW)	1	1	1	1	STD
	4SR-14916-CW	.NEEDLE (N3CW)	1	1	1	1	AP
	4SR-14916-CJ	.NEEDLE (N3CJ)	1	1	1	1	AP
	4SR-14916-EJ	.NEEDLE (N3EJ)	1	1	1	1	AP



1P85100-E070

FIG. 7 CARBURETOR

REF. NO.	PART NO.	DESCRIPTION	1P89	1P8A	1P8B	1P8C	REMARKS
10	4SR-14916-RW	.NEEDLE (N8RW)	1	1	1	1	AP
	4SR-14916-EH	.NEEDLE (N3EH)	1	1	1	1	AP
	4SR-14916-RH	.NEEDLE (N8RH)	1	1	1	1	AP
11	4MX-14919-00	.CLIP	1	1	1	1	
12	5HC-14340-A7	.VALVE ASSY	1	1	1	1	
13	5HC-14261-00	.HOLDER	1	1	1	1	
14	5HC-14126-00	.GASKET	1	1	1	1	
15	4SR-14105-00	.PILOT SCREW SET	1	1	1	1	
16	5HC-14131-00	.SPRING, THROTTLE VALVE	1	1	1	1	
17	663-14159-00	.CLIP	1	1	1	1	
18	98502-04014	.SCREW, PAN HEAD	4	4	4	4	
19	4XL-14197-10	.PIPE	2	2	2	2	
20	4XL-14196-10	.PIPE	1	1	1	1	
21	676-14548-00	.PIN, FLOAT ARM	1	1	1	1	
22	3TJ-14137-40	.CLIP	5	5	5	5	
23	4MX-14943-93	.JET, MAIN (#178)	1	1	1	1	STD
	4MX-14943-90	.JET, MAIN (#162)	1	1	1	1	AP
	4MX-14943-40	.JET, MAIN (#165)	1	1	1	1	AP
	4MX-14943-91	.JET, MAIN (#168)	1	1	1	1	AP
	4MX-14943-41	.JET, MAIN (#170)	1	1	1	1	AP
	4MX-14943-92	.JET, MAIN (#172)	1	1	1	1	AP
	4MX-14943-42	.JET, MAIN (#175)	1	1	1	1	AP
	4MX-14943-43	.JET, MAIN (#180)	1	1	1	1	AP
	4MX-14943-94	.JET, MAIN (#182)	1	1	1	1	AP
	4MX-14943-44	.JET, MAIN (#185)	1	1	1	1	AP

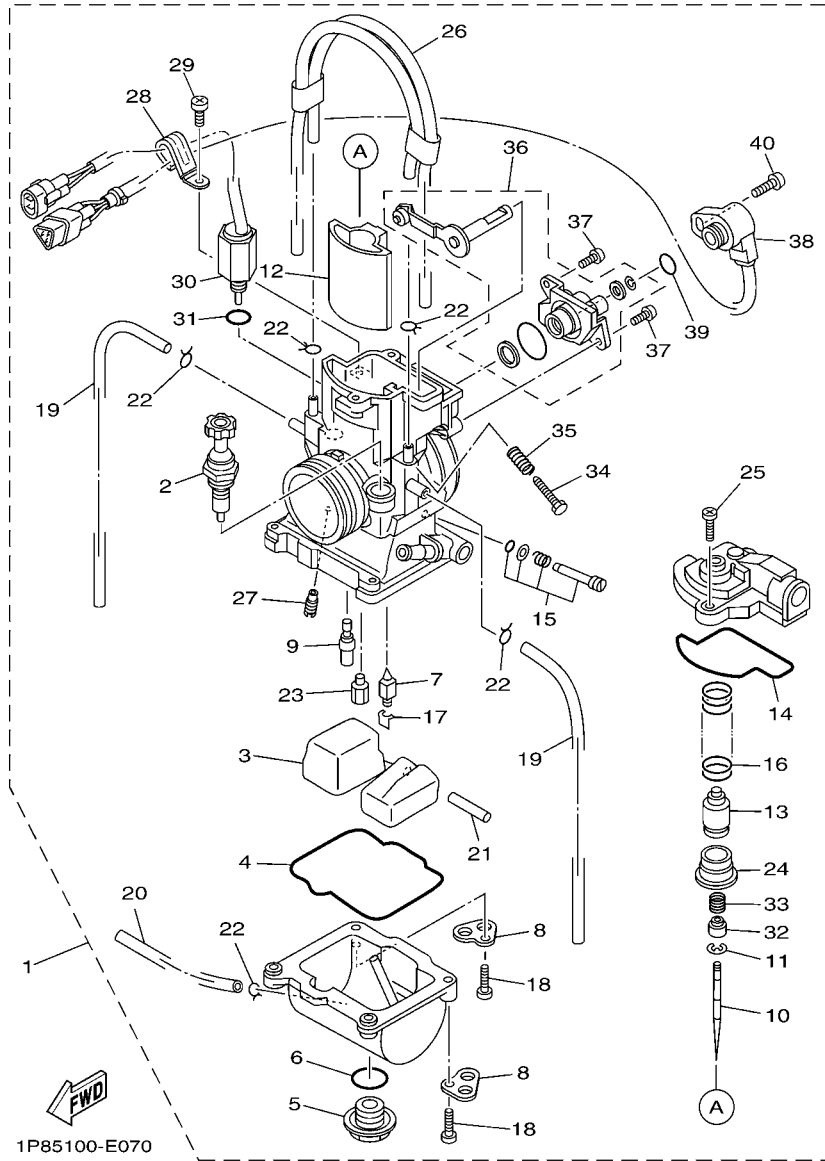
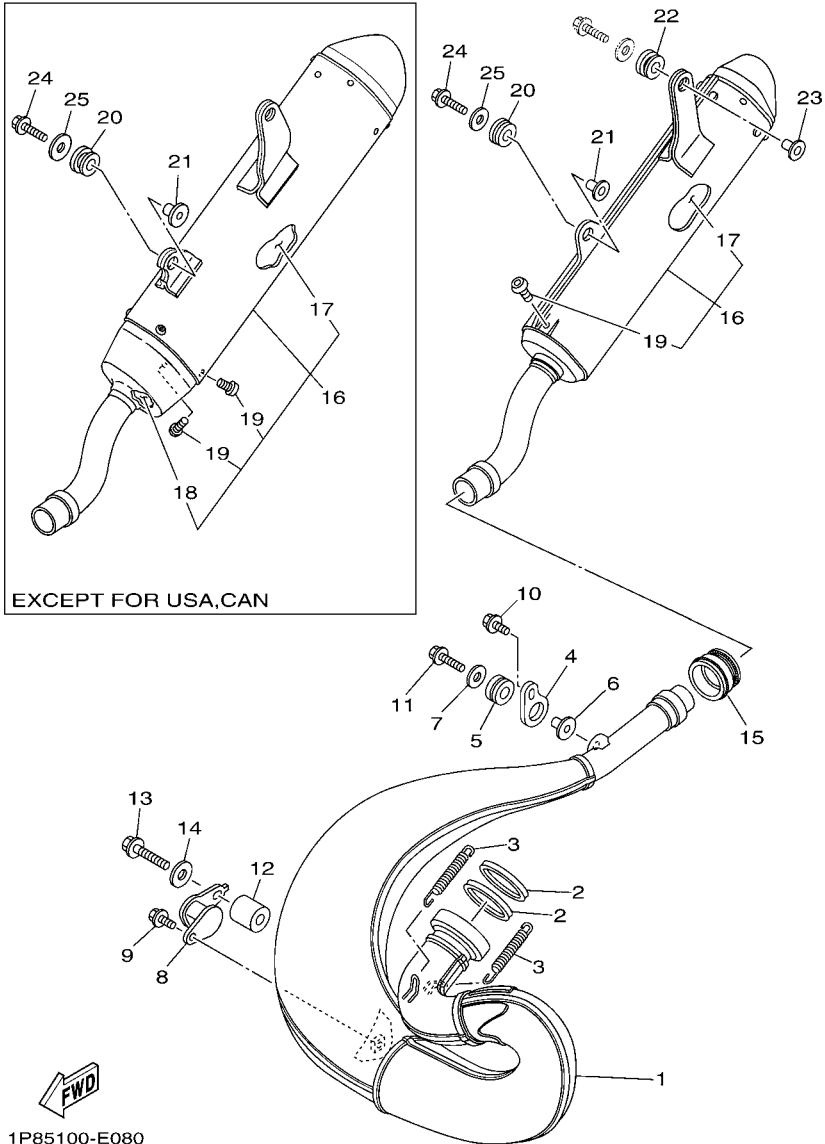

FIG. 7 CARBURETOR

REF. NO.	PART NO.	DESCRIPTION	1P89	1P8A	1P8B	1P8C	REMARKS
23	4MX-14943-95	.JET, MAIN (#188)	1	1	1	1	AP
	4MX-14943-45	.JET, MAIN (#190)	1	1	1	1	AP
24	4MX-14194-00	.RING	1	1	1	1	
25	98502-04012	.SCREW, PAN HEAD	2	2	2	2	
26	4XL-1410E-00	.HOSE	1	1	1	1	
27	4JT-1494F-07	.JET (#50)	1	1	1	1	STD
	4JT-1494F-03	.JET (#40)	1	1	1	1	AP
	4JT-1494F-09	.JET (#55)	1	1	1	1	AP
	4JT-1494F-11	.JET (#60)	1	1	1	1	AP
	4JT-1494F-13	.JET (#65)	1	1	1	1	AP
28	5HC-14146-00	.PLATE	1	1	1	1	
29	98580-04006	.SCREW, PAN HEAD	1	1	1	1	
30	5NX-1410H-10	.FUEL CUT SOLENOID VALVE	1	1	1	1	
31	4JT-14147-00	.O-RING	1	1	1	1	
32	5HC-14264-00	.COLLAR	1	1	1	1	
33	5HC-14275-00	.SPRING	1	1	1	1	
34	5HC-14922-00	.SCREW, THROTTLE	1	1	1	1	
35	5HC-14934-00	.SPRING, THROTTLE STOP	1	1	1	1	
36	1P8-14208-00	.LEVER COMP. 1	1	1	1	1	
37	5HC-14216-00	.SCREW	2	2	2	2	
38	5NX-85885-10	.THROTTLE SENSOR ASSY	1	1	1	1	
39	5NX-14562-00	.O-RING	1	1	1	1	
40	5NX-14216-00	.SCREW	1	1	1	1	



1P85100-E080

FIG. 8 EXHAUST

REF. NO.	PART NO.	DESCRIPTION	1P89	1P8A	1P8B	1P8C	REMARKS
1	1P8-14610-00	EXHAUST PIPE ASSY 1	1		1	1	
2	5MW-14642-00	SEAL, EXHAUST	2	2	2	2	
3	90507-20052	SPRING, TENSION	2	2	2	2	
4	5CU-14771-01	STAY, MUFFLER 1	1	1	1	1	
5	90480-16561	GROMMET	1	1	1	1	
6	90387-063G3	COLLAR	1	1	1	1	
7	90201-06033	WASHER, PLATE	1	1	1	1	
8	5XF-14781-00	STAY, MUFFLER 2	1	1	1	1	
9	90119-06133	BOLT, WITH WASHER	1	1	1	1	
10	90119-06133	BOLT, WITH WASHER	1	1	1	1	
11	95022-06025	BOLT, FLANGE	1	1	1	1	
12	90387-08030	COLLAR	1	1	1	1	
13	90105-08136	BOLT, FLANGE	1	1	1	1	
14	90201-08049	WASHER, PLATE	1	1	1	1	
15	3JE-14615-01	JOINT, EXHAUST 1	1	1	1	1	
16	1P8-14753-00	SILENCER, EXHAUST				1	
17	1P8-1469A-00	.FIBER				1	
18	1P8-1469E-00	.FIBER		1	1	1	
19	92012-06010	.BOLT, BUTTON HEAD				4	
20	90480-17004	GROMMET				1	
21	90387-06121	COLLAR				1	

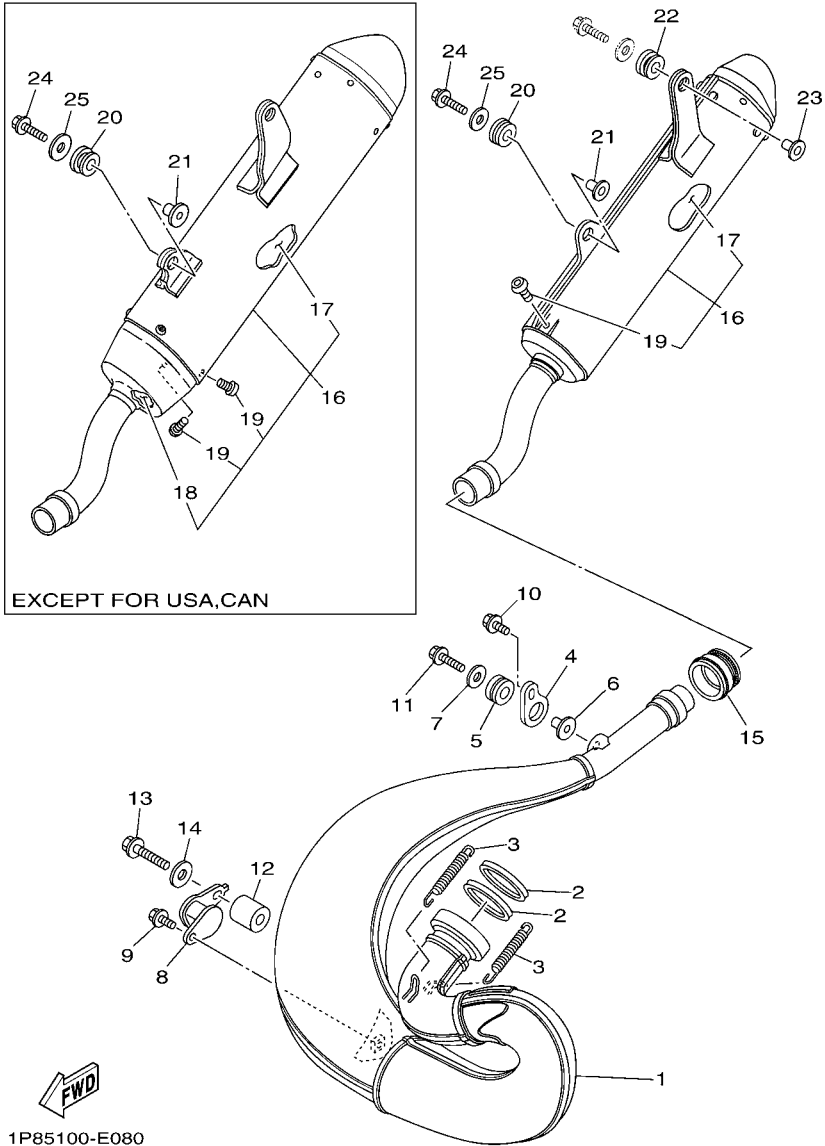
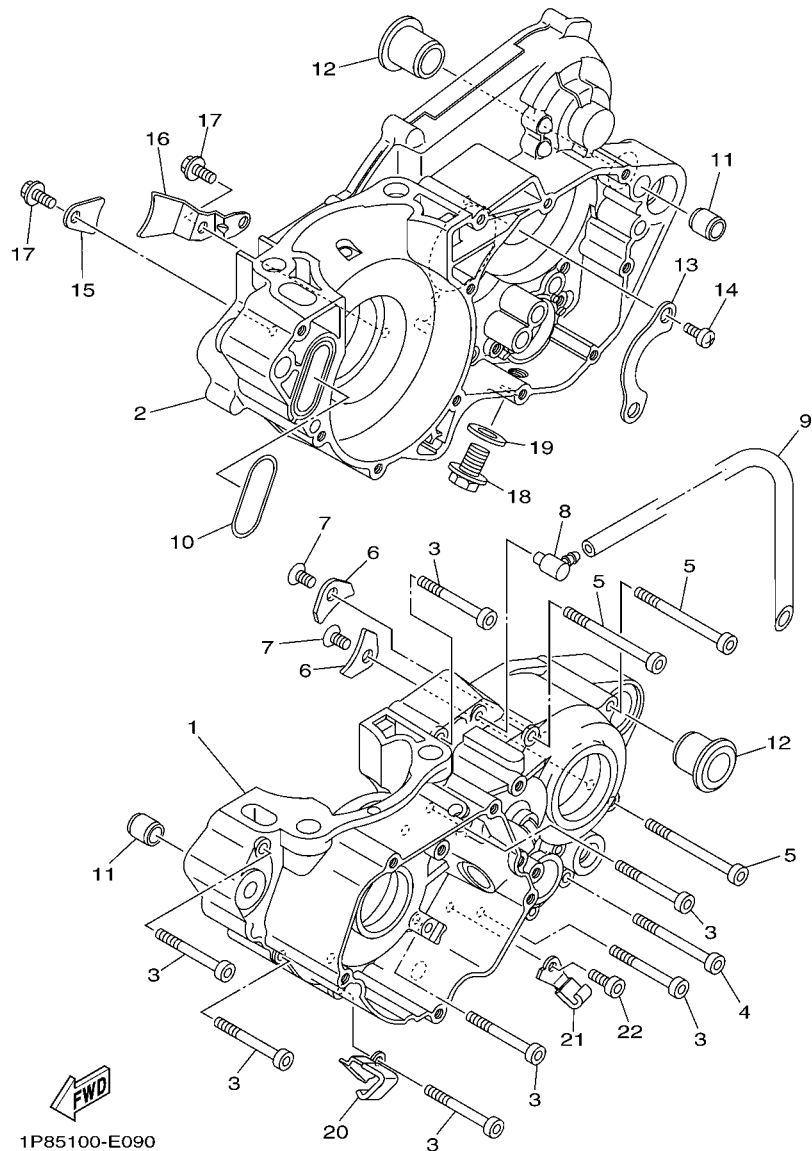

FIG. 8 EXHAUST

REF. NO.	PART NO.	DESCRIPTION	1P89	1P8A	1P8B	1P8C	REMARKS
22	90480-16404	GROMMET	1	1	1	1	
23	90387-06039	COLLAR	1	1	1	1	
24	95022-06030	BOLT, FLANGE	1	1	1	1	
25	90201-06086	WASHER, PLATE				1	



1P85100-E090

FIG. 9 CRANKCASE

REF. NO.	PART NO.	DESCRIPTION	1P89	1P8A	1P8B	1P8C	REMARKS
1	1p8-15111-01	CRANKCASE 1				1	
2	5NX-15121-00	CRANKCASE 2	1	1	1	1	
3	91312-06050	BOLT	7	7	7	7	
4	91312-06060	BOLT	1	1	1	1	
5	91312-06070	BOLT	3	3	3	3	
6	4JT-15381-01	PLATE, BEARING COVER	2	2	2	2	
7	90149-06074	SCREW	2	2	2	2	
8	353-13115-01	CONNECTOR, SUCTION PIPE	1	1	1	1	
9	90445-08376	HOSE (L330)	1	1	1	1	
10	5CU-15454-00	GASKET 1	1	1	1	1	
11	93612-16254	PIN, DOWEL	2	2	2	2	
12	90387-18007	COLLAR	2	2	2	2	
13	4L0-17471-00	PLATE, COVER	1	1	1	1	
14	90157-06008	SCREW, PAN HEAD	2	2	2	2	
15	4V4-15118-00	HOLDER	1	1	1	1	
16	5CU-15118-10	HOLDER	1	1	1	1	
17	90105-06085	BOLT, FLANGE	2	2	2	2	
18	90340-12006	PLUG, STRAIGHT SCREW	1	1	1	1	
19	90430-12227	GASKET	1	1	1	1	
20	90462-08040	CLAMP		1	1	1	
21	90462-08041	CLAMP		1	1	1	
22	91312-06012	BOLT		1	1	1	

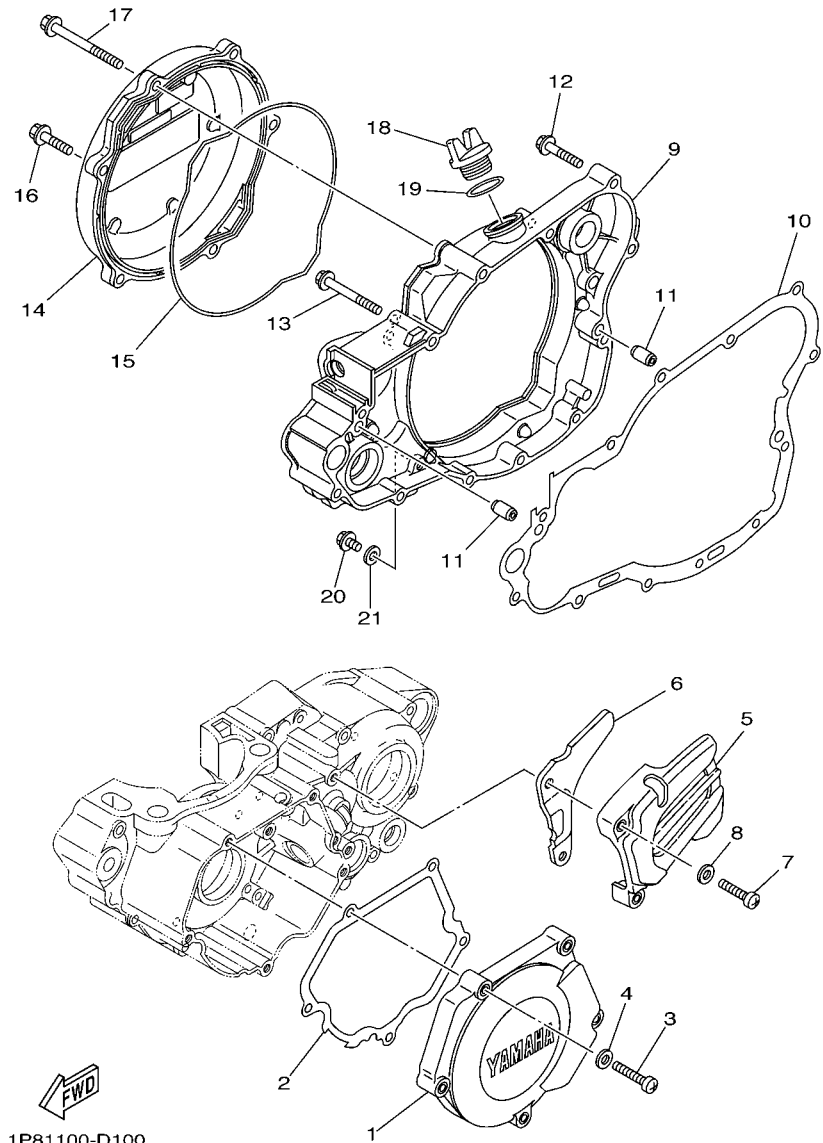

FIG. 10 CRANKCASE COVER 1

REF. NO.	PART NO.	DESCRIPTION	1P89	1P8A	1P8B	1P8C	REMARKS
1	5CU-15411-10	COVER, CRANKCASE 1	1	1	1	1	
2	5CU-15451-00	GASKET, CRANKCASE COVER 1	1	1	1	1	
3	92502-06030	SCREW, PAN HEAD	5	5	5	5	
4	92902-06600	WASHER, PLATE	5	5	5	5	
5	1P8-15421-10	COVER, CRANKCASE 2	1	1	1	1	
6	5HC-17466-00	GUIDE, CHAIN	1	1	1	1	
7	92502-06030	SCREW, PAN HEAD	2	2	2	2	
8	92902-06600	WASHER, PLATE	2	2	2	2	
9	5NX-15431-00	COVER, CRANKCASE 3	1	1	1	1	
10	5CU-15462-00	GASKET, CRANKCASE COVER 3	1	1	1	1	
11	99530-08016	PIN, DOWEL	2	2	2	2	
12	95022-06030	BOLT, FLANGE	8	8	8	8	
13	95022-06050	BOLT, FLANGE	1	1	1	1	
14	5MW-15415-10	COVER, GENERATOR	1	1	1	1	
15	5CU-15463-00	GASKET, COVER PINION 2	1	1	1	1	
16	95022-06025	BOLT, FLANGE	5	5	5	5	
17	95022-06065	BOLT, FLANGE	1	1	1	1	
18	3Y1-15363-00	PLUG, OIL	1	1	1	1	
19	93210-19123	O-RING	1	1	1	1	
20	95022-06010	BOLT, FLANGE	1	1	1	1	
21	90430-06014	GASKET	1	1	1	1	

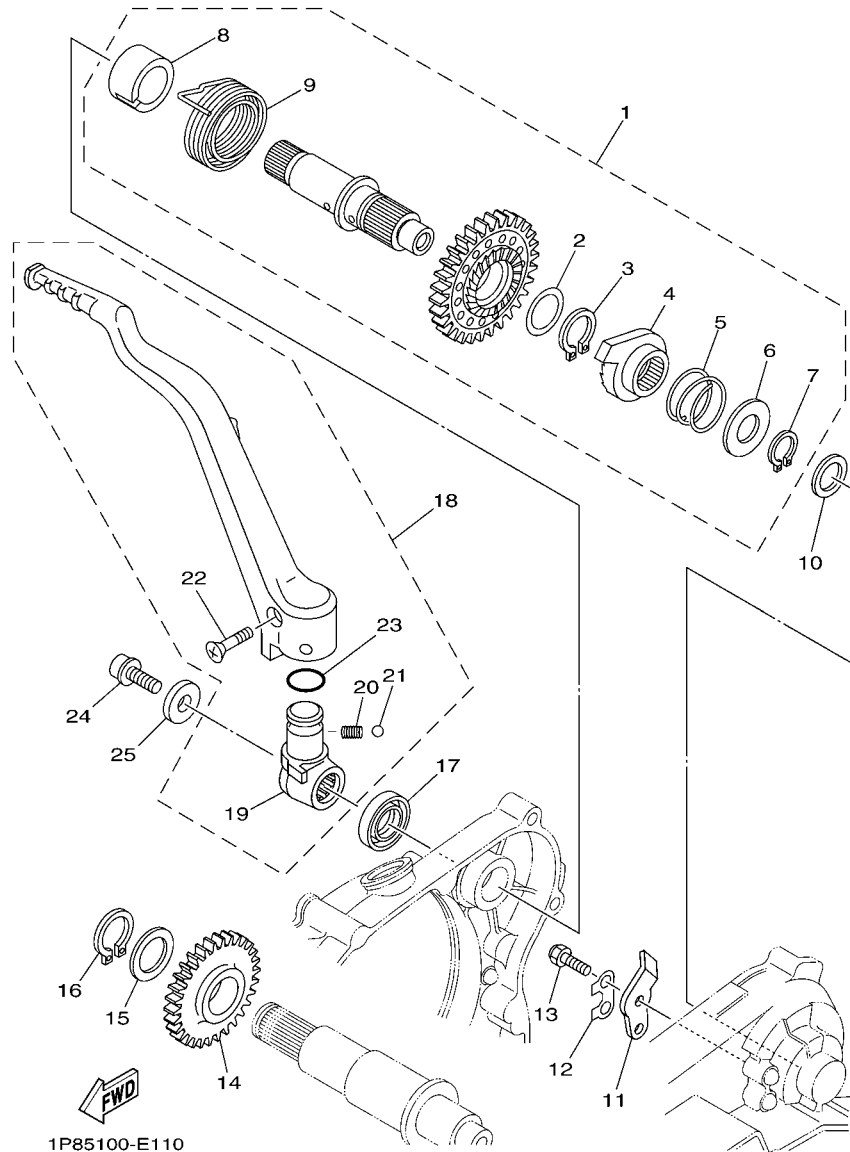
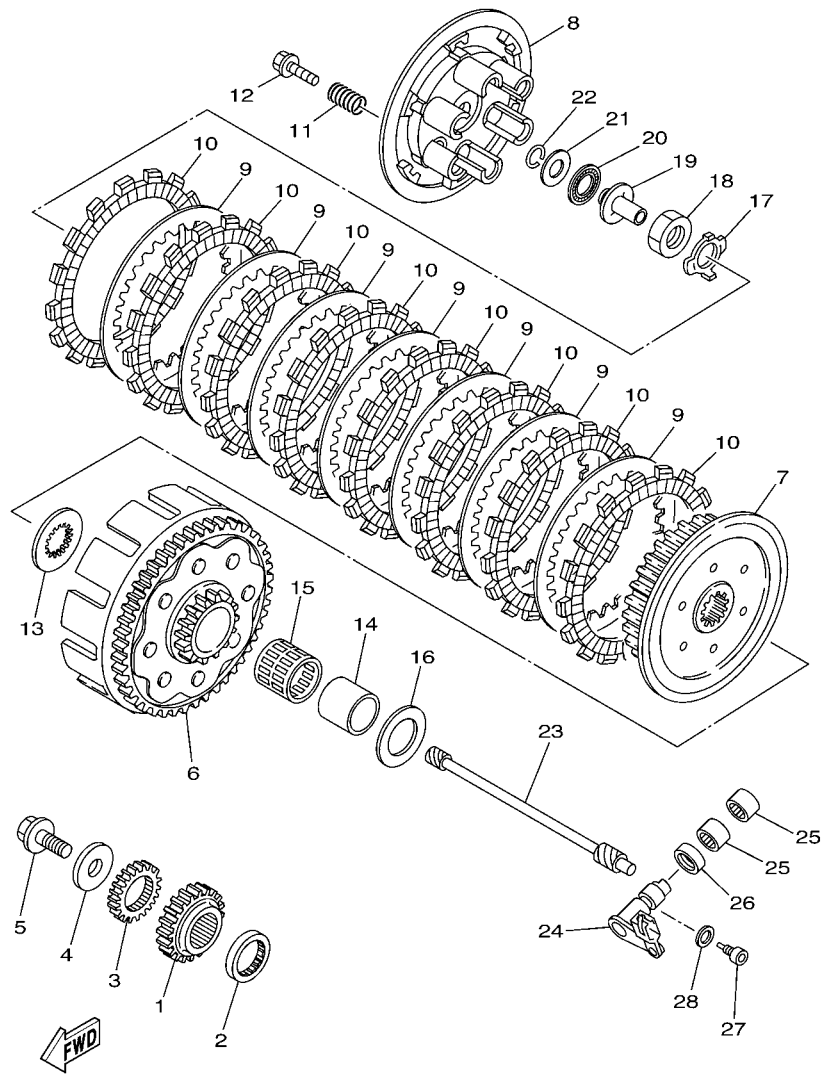

FIG. 11 STARTER

REF. NO.	PART NO.	DESCRIPTION	1P89	1P8A	1P8B	1P8C	REMARKS
1	5NX-15601-10	KICK SHAFT ASSY	1	1	1	1	
2	90201-20685	.WASHER, PLATE (T=0.5)	1	1	1	1	
3	93410-20038	.CIRCLIP	1	1	1	1	
4	4GY-15671-00	.WHEEL, RATCHET	1	1	1	1	
5	90501-16016	.SPRING, COMPRESSION	1	1	1	1	
6	90201-167P7	.WASHER, PLATE	1	1	1	1	
7	99009-16400	.CIRCLIP	1	1	1	1	
8	5NL-15664-00	.GUIDE, SPRING	1	1	1	1	
9	90508-30743	.SPRING, TORSION	1	1	1	1	
10	90201-162H4	WASHER, PLATE	1	1	1	1	
11	214-15674-00	GUIDE, RATCHET WHEEL	1	1	1	1	
12	214-15686-00	WASHER, LOCK	1	1	1	1	
13	97022-06016	BOLT	2	2	2	2	
14	5CU-15651-00	GEAR, KICK IDLE	1	1	1	1	
15	90201-20276	WASHER, PLATE (T=1.0)	1	1	1	1	
16	99009-20400	CIRCLIP	1	1	1	1	
17	93102-18278	OIL SEAL	1	1	1	1	
18	5NX-15620-20	KICK CRANK ASSY	1	1	1	1	
19	5NX-15621-10	.BOSS, KICK CRANK	1	1	1	1	
20	90501-147A5	.SPRING, COMPRESSION	1	1	1	1	
21	93507-32009	.BALL	1	1	1	1	
22	90151-06045	.SCREW, COUNTERSUNK	1	1	1	1	
23	93210-17570	.O-RING	1	1	1	1	
24	90110-08052	BOLT, HEXAGON SOCKET HEAD	1	1	1	1	
25	90201-08048	WASHER, PLATE	1	1	1	1	

FIG. 12 CLUTCH



5NX1100-A120

REF. NO.	PART NO.	DESCRIPTION	1P89	1P8A	1P8B	1P8C	REMARKS
1	5DJ-16111-00	GEAR, PRIMARY DRIVE	1	1	1	1	
2	5MW-16113-00	WASHER, THRUST 1	1	1	1	1	
3	5CU-11956-00	GEAR, GOVERNOR DRIVE	1	1	1	1	
4	90201-105P3	WASHER, PLATE	1	1	1	1	
5	90105-10445	BOLT, FLANGE	1	1	1	1	
6	5DJ-16150-00	PRIMARY DRIVEN GEAR COMP.	1	1	1	1	
7	5NX-16371-00	BOSS, CLUTCH	1	1	1	1	
8	5JG-16351-00	PLATE, PRESSURE 1	1	1	1	1	
9	4X7-16325-00	PLATE, CLUTCH 2	7	7	7	7	
10	3XK-16321-00	PLATE, FRICTION	8	8	8	8	
11	90501-237L0	SPRING, COMPRESSION	6	6	6	6	
12	90159-06010	SCREW, WITH WASHER	6	6	6	6	
13	5CU-16154-00	PLATE, THRUST 1	1	1	1	1	
14	2VM-16181-00	SPACER 1	1	1	1	1	
15	93310-230T7	BEARING	1	1	1	1	
16	2K7-16154-00	PLATE, THRUST 1	1	1	1	1	
17	90215-20231	WASHER, LOCK	1	1	1	1	
18	90170-20255	NUT	1	1	1	1	
19	4XL-16356-00	ROD, PUSH 1	1	1	1	1	
20	93340-21505	BEARING	1	1	1	1	
21	90201-125L6	WASHER, PLATE	1	1	1	1	
22	93440-10085	CIRCLIP	1	1	1	1	
23	1P8-16357-00	ROD, PUSH 2	1	1	1	1	
24	5CU-16380-10	PUSH LEVER ASSY	1	1	1	1	
25	93315-11206	BEARING	2	2	2	2	
26	93102-12224	OIL SEAL	1	1	1	1	
27	90109-05009	BOLT	1	1	1	1	

FIG. 12 CLUTCH

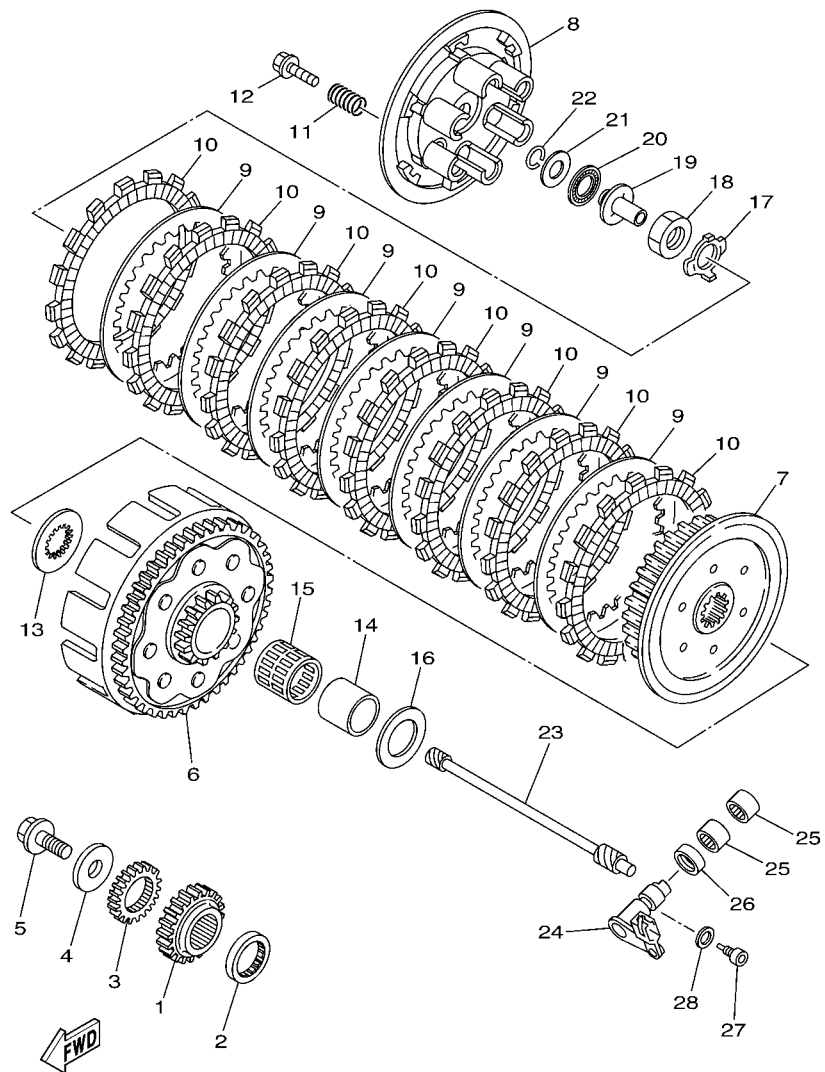

5NX1100-A120

REF. NO.	PART NO.	DESCRIPTION	1P89	1P8A	1P8B	1P8C	REMARKS
28	90430-05242	GASKET	1	1	1	1	

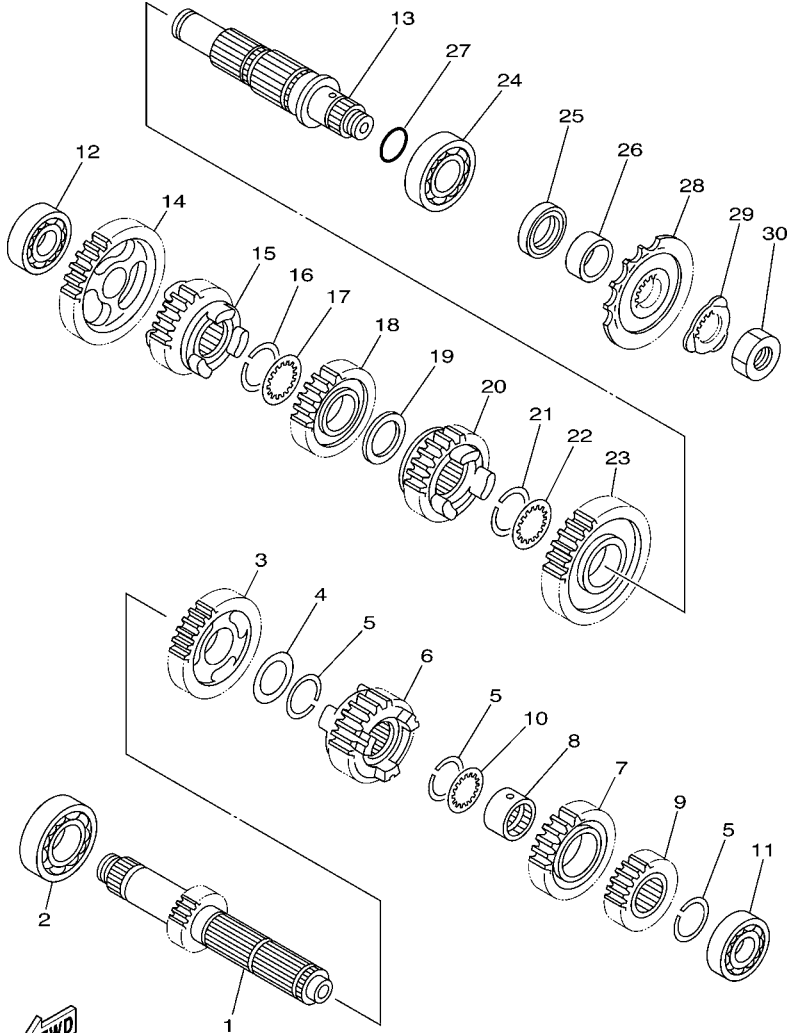

5CU1100-9130

FIG. 13 TRANSMISSION

REF. NO.	PART NO.	DESCRIPTION	1P89	1P8A	1P8B	1P8C	REMARKS
1	5BE-17411-00	AXLE, MAIN (14T)	1	1	1	1	
2	93306-20540	BEARING	1	1	1	1	
3	5BE-17151-00	GEAR, 5TH PINION (21T)	1	1	1	1	
4	90201-253K0	WASHER, PLATE (T=1.0)	1	1	1	1	
5	93440-25084	CIRCLIP	3	3	3	3	
6	5CU-17131-01	GEAR, 3RD PINION (18T)	1	1	1	1	
7	5BE-17141-30	GEAR, 4TH PINION (22T)	1	1	1	1	
8	90387-2113G	COLLAR	1	1	1	1	
9	5JG-17121-10	GEAR, 2ND PINION (15T)	1	1	1	1	
10	90209-21332	WASHER	1	1	1	1	
11	93306-00442	BEARING	1	1	1	1	
12	93306-00426	BEARING	1	1	1	1	
13	5BE-17402-00	DRIVE AXLE ASSY	1	1	1	1	
14	5BE-17211-00	GEAR, 1ST WHEEL (27T)	1	1	1	1	
15	5BE-17251-10	GEAR, 5TH WHEEL (20T)	1	1	1	1	
16	93440-25084	CIRCLIP	1	1	1	1	
17	90209-21332	WASHER	1	1	1	1	
18	5BE-17231-00	GEAR, 3RD WHEEL (23T)	1	1	1	1	
19	90201-253K0	WASHER, PLATE (T=1.0)	1	1	1	1	
20	5JG-17241-00	GEAR, 4TH WHEEL (24T)	1	1	1	1	
21	93440-28062	CIRCLIP	1	1	1	1	
22	90209-26348	WASHER	1	1	1	1	
23	5JG-17221-10	GEAR, 2ND WHEEL (23T)	1	1	1	1	
24	93306-20574	BEARING	1	1	1	1	
25	93102-32337	OIL SEAL	1	1	1	1	
26	90387-2515B	COLLAR	1	1	1	1	
27	93210-22298	O-RING	1	1	1	1	

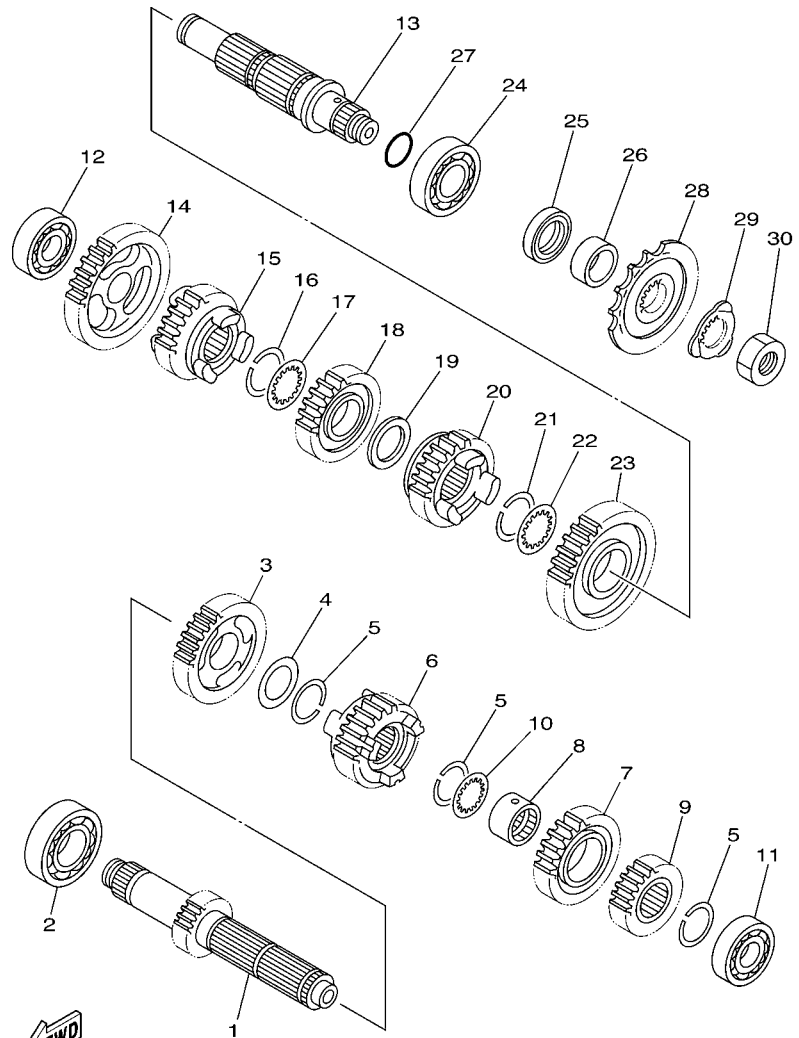

FWD
5CU1100-9130

FIG. 13 TRANSMISSION

REF. NO.	PART NO.	DESCRIPTION	1P89	1P8A	1P8B	1P8C	REMARKS
28	9383E-14215	SPROCKET, DRIVE (14T)	1	1	1	1	STD
	9383E-13216	SPROCKET, DRIVE (13T)	1	1	1	1	AP
29	90215-21256	WASHER, LOCK	1	1	1	1	
30	90179-20255	NUT	1	1	1	1	

FIG. 14 SHIFT CAM & FORK

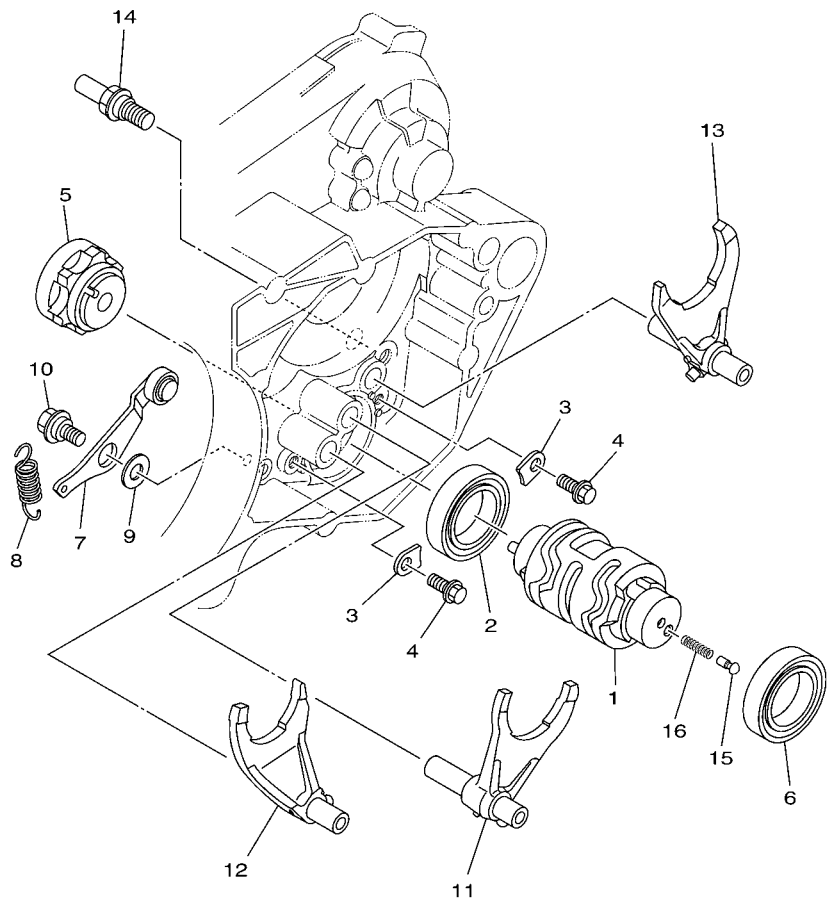

REF. NO.	PART NO.	DESCRIPTION	1P89	1P8A	1P8B	1P8C	REMARKS
1	1P8-18541-00	CAM, SHIFT	1	1	1	1	
2	93306-90506	BEARING	1	1	1	1	
3	5DH-18562-00	PLATE, STOPPER 2	2	2	2	2	
4	90105-06081	BOLT, FLANGE	2	2	2	2	
5	4EW-18185-00	SEGMENT	1	1	1	1	
6	93306-90501	BEARING	1	1	1	1	
7	5CU-18140-01	STOPPER LEVER ASSY	1	1	1	1	
8	90507-14064	SPRING, TENSION	1	1	1	1	
9	90201-06013	WASHER, PLATE	1	1	1	1	
10	90109-06198	BOLT	1	1	1	1	
11	5BE-18501-20	FORK, SHIFT 1	1	1	1	1	
12	5BE-18502-20	FORK, SHIFT 2	1	1	1	1	
13	5CU-18503-20	FORK, SHIFT 3	1	1	1	1	
14	4BR-18127-10	STOPPER, SCREW	1	1	1	1	
15	4UN-18542-00	POINT, NEUTRAL		1	1	1	
16	90501-06022	SPRING, COMPRESSION		1	1	1	

1P85100-E140

FIG. 15 SHIFT SHAFT

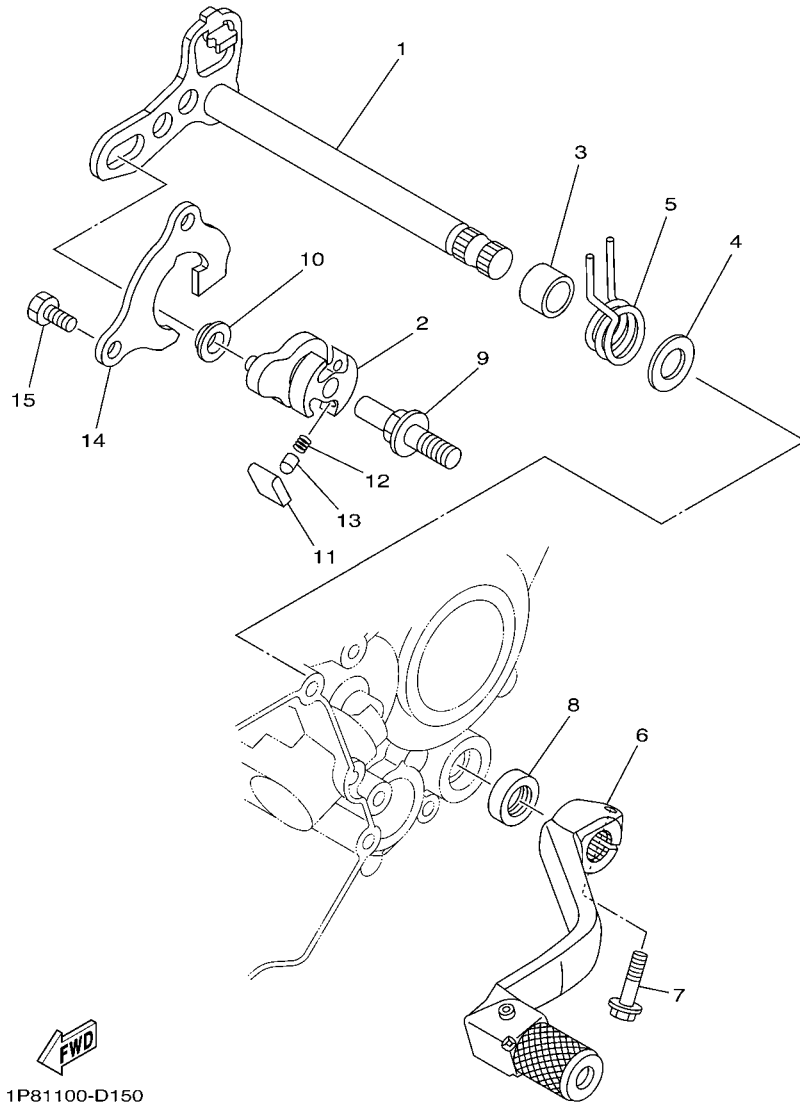

REF. NO.	PART NO.	DESCRIPTION	1P89	1P8A	1P8B	1P8C	REMARKS
1	5CU-18101-10	SHIFT SHAFT ASSY	1	1	1	1	
2	5MW-18122-01	LEVER, SHIFT 2	1	1	1	1	
3	90387-124F4	COLLAR	1	1	1	1	
4	90201-12575	WASHER, PLATE	1	1	1	1	
5	90508-291A8	SPRING, TORSION	1	1	1	1	
6	1C3-18110-00	SHIFT PEDAL ASSY	1	1	1	1	
7	95022-06020	BOLT, FLANGE	1	1	1	1	
8	93102-12224	OIL SEAL	1	1	1	1	
9	3XJ-18173-10	PIN, SHIFT	1	1	1	1	
10	3XJ-18178-00	ROLLER, SHIFT LEVER	1	1	1	1	
11	3XJ-18182-00	PAWL, SHIFTER	2	2	2	2	
12	90501-052G5	SPRING, COMPRESSION	2	2	2	2	
13	3XJ-18184-00	PIN, PAWL	2	2	2	2	
14	5CU-18172-00	GUIDE, SHIFT	1	1	1	1	
15	90101-06041	BOLT	2	2	2	2	

1P81100-D150

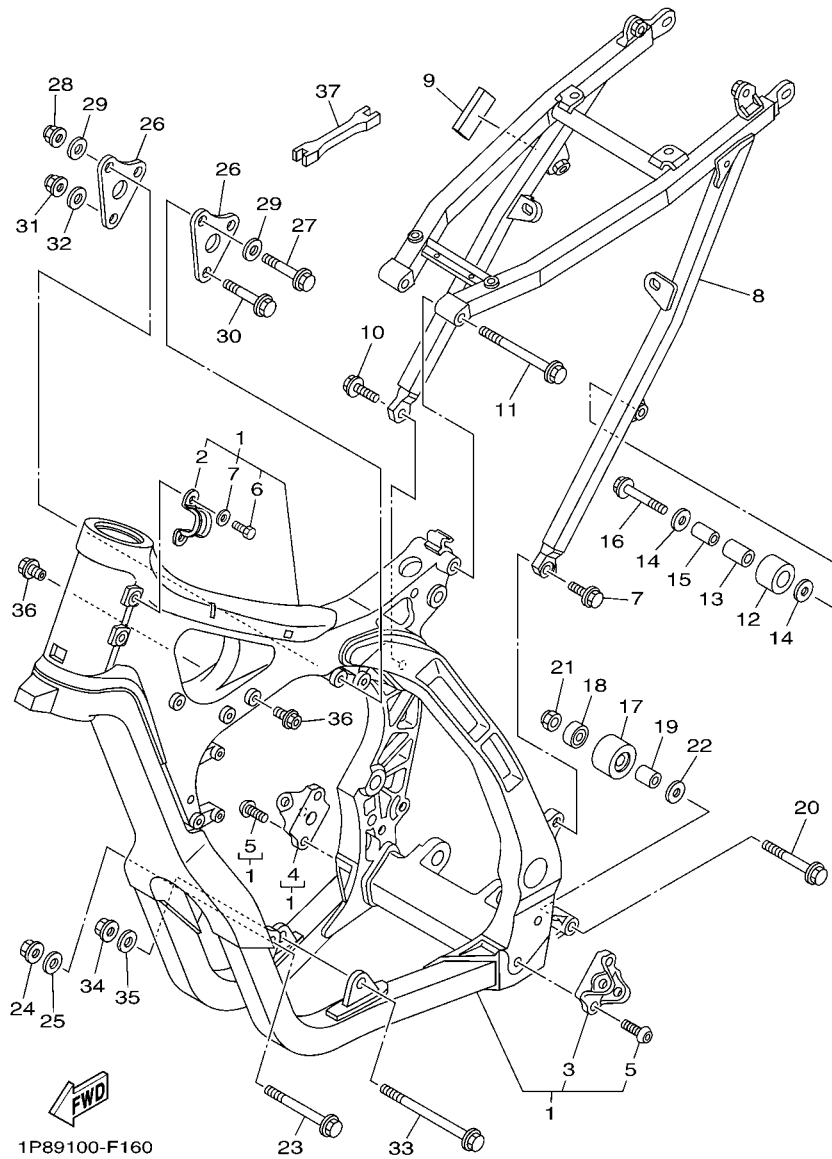

FIG. 16 FRAME

REF. NO.	PART NO.	DESCRIPTION	1P89	1P8A	1P8B	1P8C	REMARKS
1	1P8-21101-50	FRONT FRAME COMP.	1	1	1	1	
2	1C3-21336-00	.CLAMP, WIRE HARNESS 2	1	1	1	1	
3	1C3-21447-10	.BRACKET, FOOTREST	1	1	1	1	
4	1C3-21448-10	.BRACKET, FOOTREST	1	1	1	1	
5	90149-10031	.SCREW	4	4	4	4	
6	97004-05012	.BOLT	2	2	2	2	
7	92904-05600	.WASHER	2	2	2	2	
8	1C3-21190-90	REAR FRAME COMP.	1	1	1	1	
9	5GJ-21717-00	DAMPER	1	1	1	1	
10	90105-08085	BOLT, FLANGE	2	2	2	2	
11	90105-08132	BOLT, FLANGE	1	1	1	1	
12	30X-22178-00	TENSIONER	1	1	1	1	
13	4V4-22184-00	BUSH	1	1	1	1	
14	90201-08045	WASHER, PLATE	2	2	2	2	
15	90387-08041	COLLAR	1	1	1	1	
16	95022-08040	BOLT, FLANGE	1	1	1	1	
17	3JD-22178-20	TENSIONER	1	1	1	1	
18	93300-60839	BEARING	1	1	1	1	
19	90387-086N4	COLLAR	1	1	1	1	
20	90105-08133	BOLT, FLANGE	1	1	1	1	
21	90185-08009	NUT, SELF-LOCKING	1	1	1	1	
22	90201-08043	WASHER, PLATE	1	1	1	1	
23	90105-10172	BOLT, FLANGE	1	1	1	1	
24	90179-10658	NUT	1	1	1	1	
25	92902-10200	WASHER	1	1	1	1	
26	5NX-21425-00	BRACKET, REAR UPPER 1	2	2	2	2	
27	90105-08131	BOLT, FLANGE	2	2	2	2	

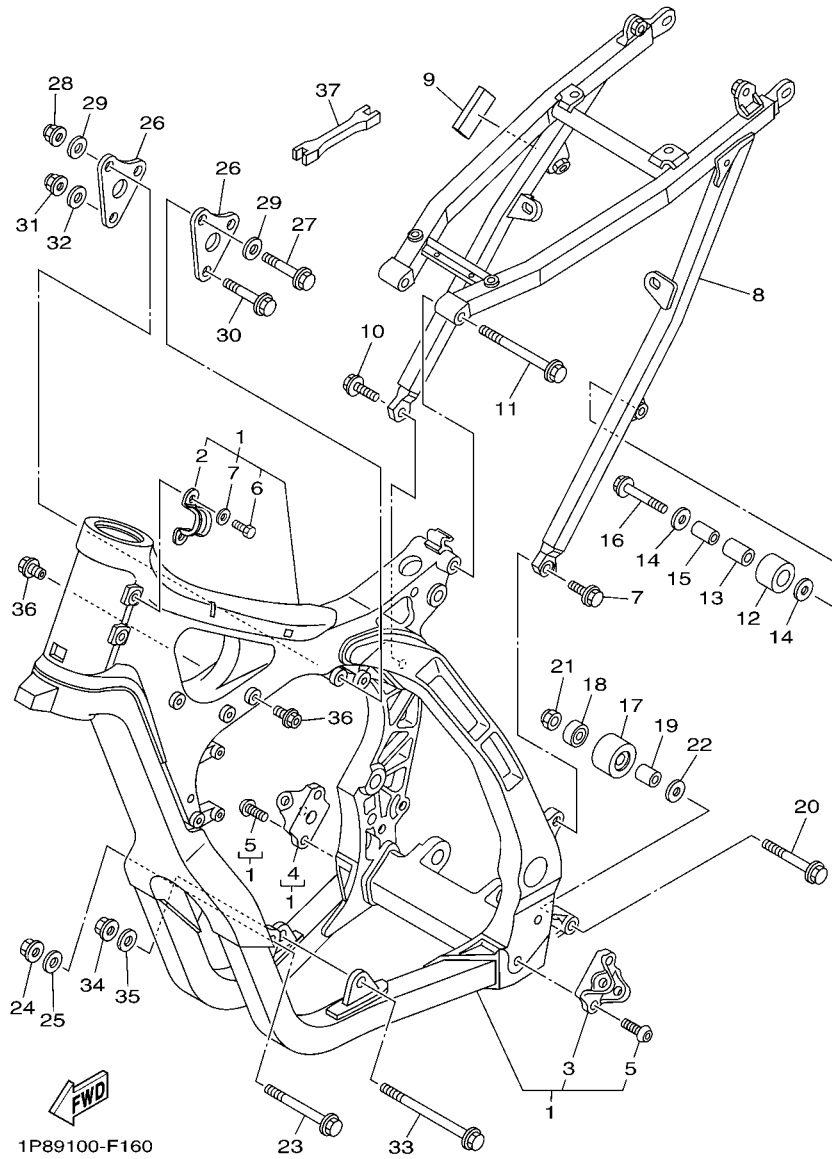

FIG. 16 FRAME

REF. NO.	PART NO.	DESCRIPTION	1P89	1P8A	1P8B	1P8C	REMARKS
28	90179-08674	NUT	2	2	2	2	
29	90201-08055	WASHER, PLATE	4	4	4	4	
30	90105-10173	BOLT, FLANGE	1	1	1	1	
31	90179-10658	NUT	1	1	1	1	
32	92902-10200	WASHER	1	1	1	1	
33	90105-10174	BOLT, FLANGE	1	1	1	1	
34	90179-10658	NUT	1	1	1	1	
35	92902-10200	WASHER	1	1	1	1	
36	1C3-21244-10	NUT	2	2	2	2	
37	5ET-28166-10	WRENCH, HEXAGON	1	1	1	1	

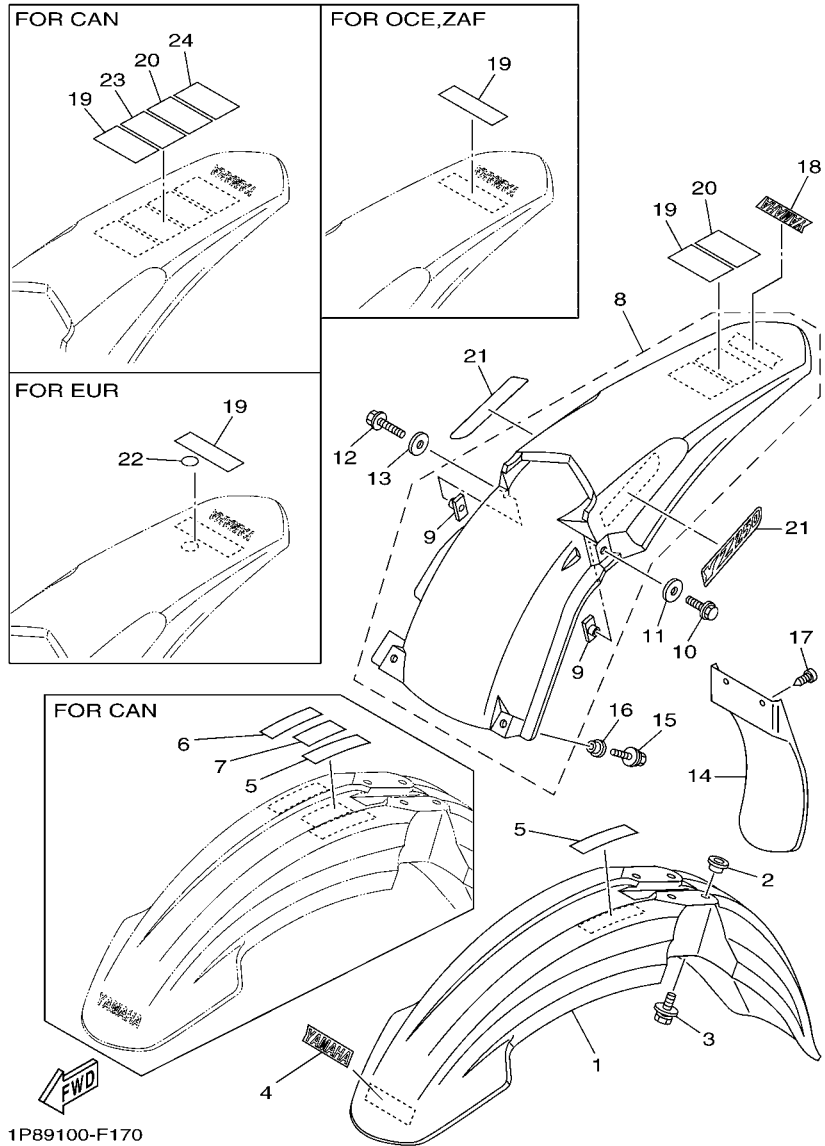
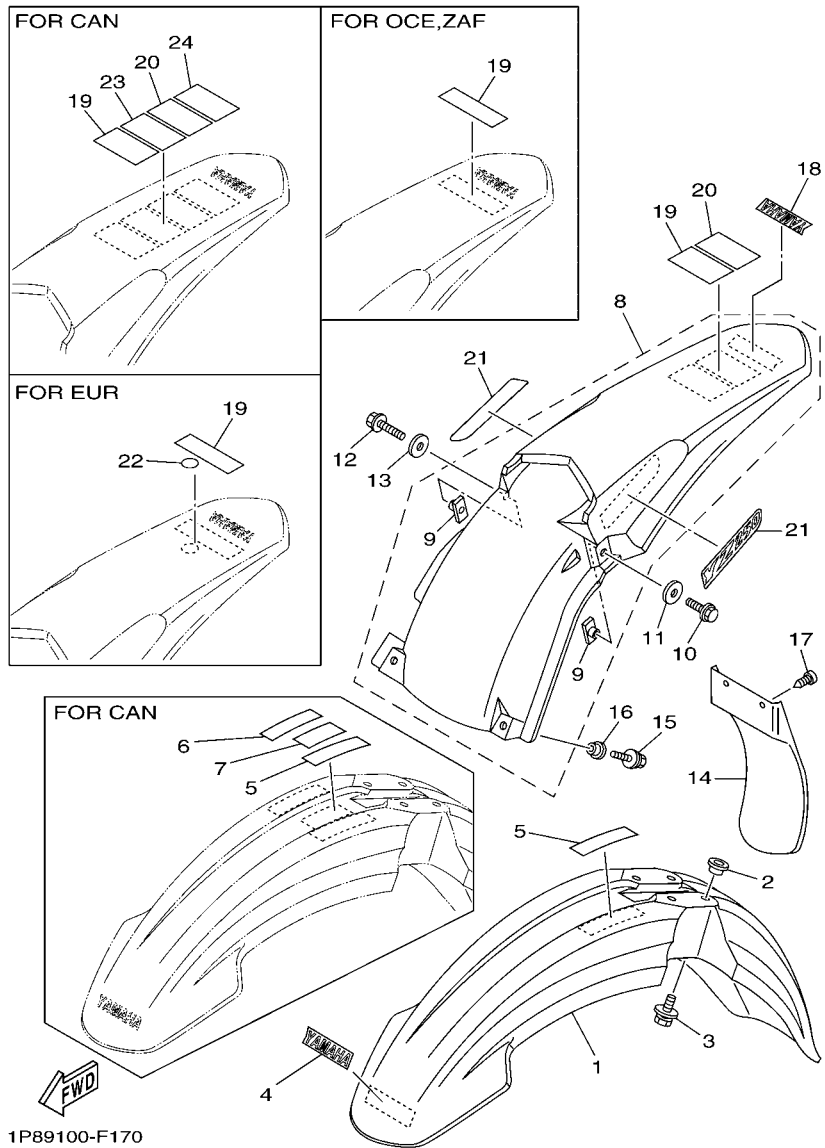

FIG. 17 FENDER

REF. NO.	PART NO.	DESCRIPTION	1P89	1P8A	1P8B	1P8C	REMARKS
1	1C3-21511-51	FENDER, FRONT	1	1	1	1	
2	90387-06090	COLLAR	4	4	4	4	
3	90119-06147	BOLT, WITH WASHER	4	4	4	4	
4	4ES-2153E-01	EMBLEM, YAMAHA	1	1	1	1	
5	N/A						
6	N/A						
7	N/A						
8	5XE-21610-10	REAR FENDER COMP.	1	1	1	1	
9	5XE-21635-10	.NUT, REAR FENDER	2	2	2	2	
10	90105-06099	BOLT, FLANGE	1	1	1	1	
11	90201-06032	WASHER, PLATE	1	1	1	1	
12	90105-06101	BOLT, FLANGE	1	1	1	1	
13	90201-06033	WASHER, PLATE	1	1	1	1	
14	5UN-21642-10	GUARD, FLAP	1	1	1	1	
15	90119-06149	BOLT, WITH WASHER	2	2	2	2	
16	90387-06009	COLLAR	2	2	2	2	
17	97702-60016	SCREW, TAPPING	2	2	2	2	
18	4ES-2153E-01	EMBLEM, YAMAHA	1	1	1	1	
19	5PA-21168-00	LABEL, CAUTION				1	
20	N/A						
21	1P8-2163G-00	EMBLEM 1	2	2	2	2	
22	N/A						
23	N/A						

FIG. 17 FENDER



REF. NO.	PART NO.	DESCRIPTION	1P89	1P8A	1P8B	1P8C	REMARKS
24	N/A						

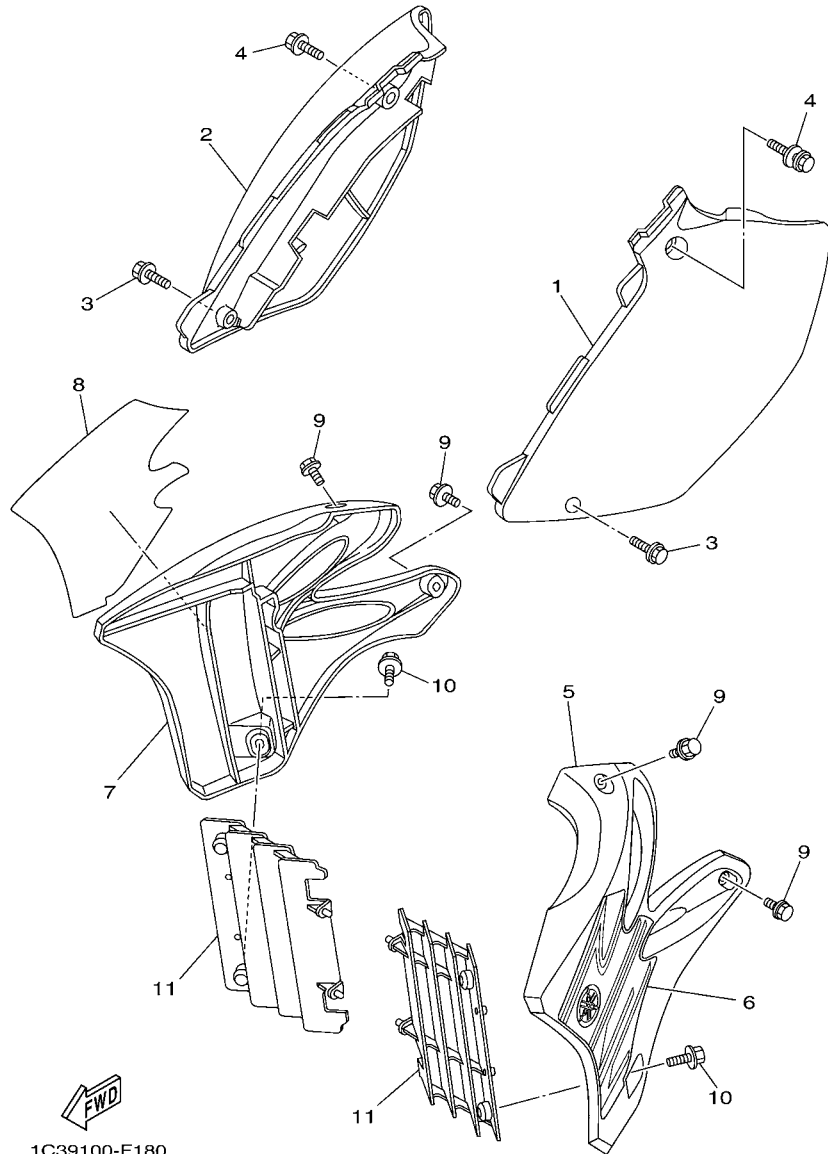
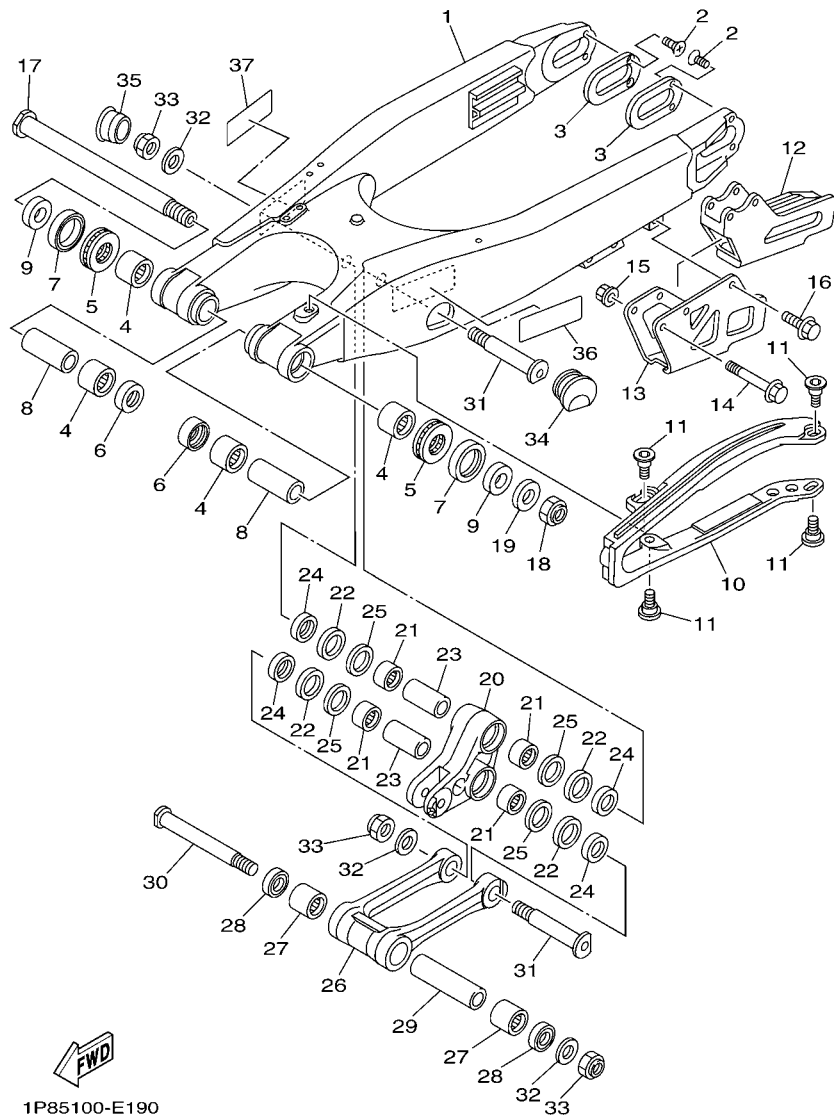

FIG. 18 SIDE COVER

REF. NO.	PART NO.	DESCRIPTION	1P89	1P8A	1P8B	1P8C	REMARKS
1	5NY-21711-00	COVER, SIDE 1	1	1	1	1	
2	1C3-21721-50	COVER, SIDE 2				1	
3	90105-06103	BOLT, FLANGE	2	2	2	2	
4	90119-08095	BOLT, WITH WASHER	2	2	2	2	
5	5XE-21730-00	SIDE COVER ASSY 3	1	1	1	1	
6	1C3-2173E-20	GRAPHIC 1	1	1	1	1	
7	5XE-21740-00	SIDE COVER ASSY 4	1	1	1	1	
8	1C3-2173F-20	GRAPHIC 2	1	1	1	1	
9	90105-06064	BOLT, FLANGE	4	4	4	4	
10	90159-06021	SCREW, WITH WASHER	2	2	2	2	
11	5NL-2172A-20	PANEL 1	2	2	2	2	

FIG. 19 REAR ARM



1P85100-E190

REF. NO.	PART NO.	DESCRIPTION	1P89	1P8A	1P8B	1P8C	REMARKS
1	1C3-22110-50	REAR ARM COMP.	1	1	1	1	
2	90151-04003	SCREW, COUNTERSUNK	4	4	4	4	
3	1P8-22355-00	PATCH	2	2	2	2	
4	93317-22262	BEARING	4	4	4	4	
5	93342-22217	BEARING	2	2	2	2	
6	93106-22002	OIL SEAL	2	2	2	2	
7	93109-28043	OIL SEAL	2	2	2	2	
8	90387-18004	COLLAR	2	2	2	2	
9	90387-18012	COLLAR	2	2	2	2	
10	1C3-22151-00	SEAL, GUARD	1	1	1	1	
11	1C3-22969-90	SCREW, 1	4	4	4	4	
12	1C3-22199-10	SUPPORT, CHAIN	1	1	1	1	
13	1C3-22128-00	COVER, THRUST 1	1	1	1	1	
14	90105-06104	BOLT, FLANGE	2	2	2	2	
15	90179-06028	NUT	2	2	2	2	
16	90105-06105	BOLT, FLANGE	1	1	1	1	
17	1C3-22141-10	SHAFT, PIVOT	1	1	1	1	
18	90185-16002	NUT, SELF-LOCKING	1	1	1	1	
19	90201-16018	WASHER, PLATE	1	1	1	1	
20	1C3-2217A-00	ARM, RELAY	1	1	1	1	
21	93315-32166	BEARING	4	4	4	4	
22	93109-25001	OIL SEAL	4	4	4	4	
23	90387-16010	COLLAR	2	2	2	2	
24	90209-16011	WASHER	4	4	4	4	
25	90201-21014	WASHER, PLATE	4	4	4	4	
26	1C3-2217F-50	ROD, CONNECTING 1	1	1	1	1	
27	93315-32166	BEARING	2	2	2	2	

FIG. 19 REAR ARM

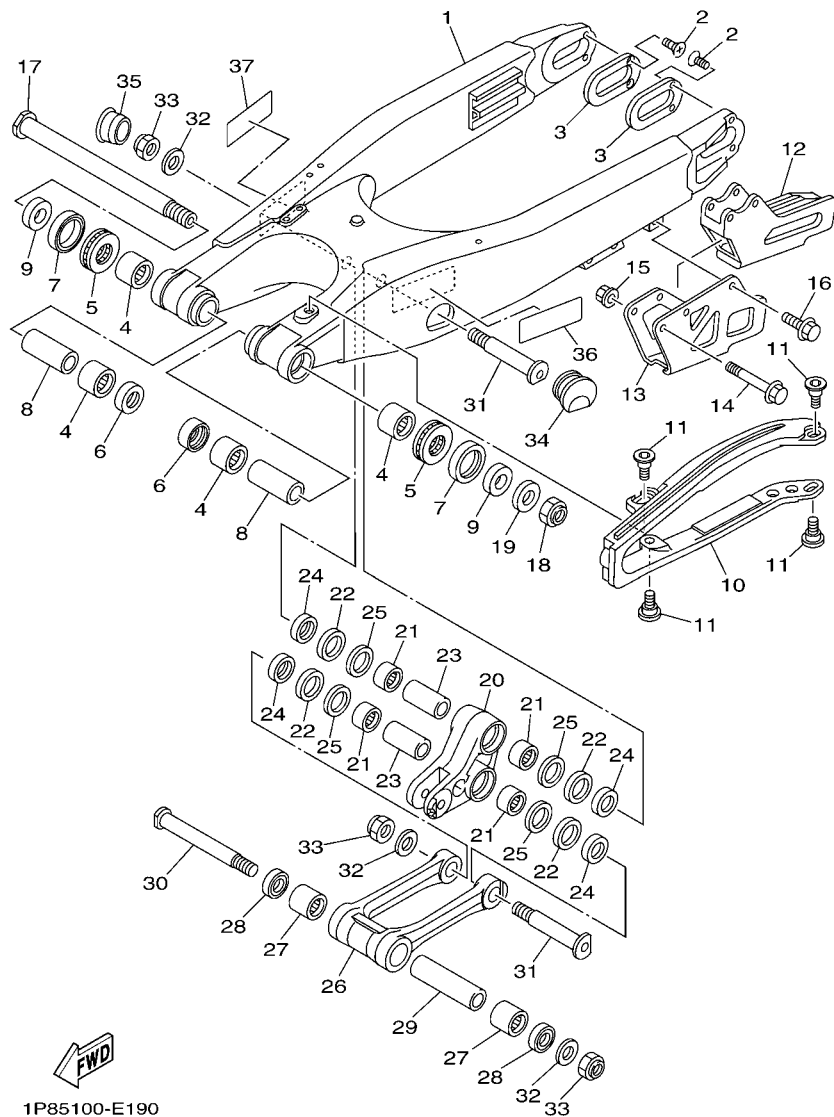

1P85100-E190

REF. NO.	PART NO.	DESCRIPTION					REMARKS
			1P89	1P8A	1P8B	1P8C	
28	93109-21001	OIL SEAL	2	2	2	2	
29	90387-14005	COLLAR	1	1	1	1	
30	1C3-22121-00	SHAFT 1	1	1	1	1	
31	1C3-22122-00	SHAFT 2	2	2	2	2	
32	90201-14020	WASHER, PLATE	3	3	3	3	
33	90185-14010	NUT, SELF-LOCKING	3	3	3	3	
34	1C3-2135F-00	COVER	1	1	1	1	
35	1C3-2139R-00	COVER 2	1	1	1	1	
36	3RV-21668-A0	LABEL, TIRE	1	1		1	
37	N/A						

FIG. 20 REAR SUSPENSION

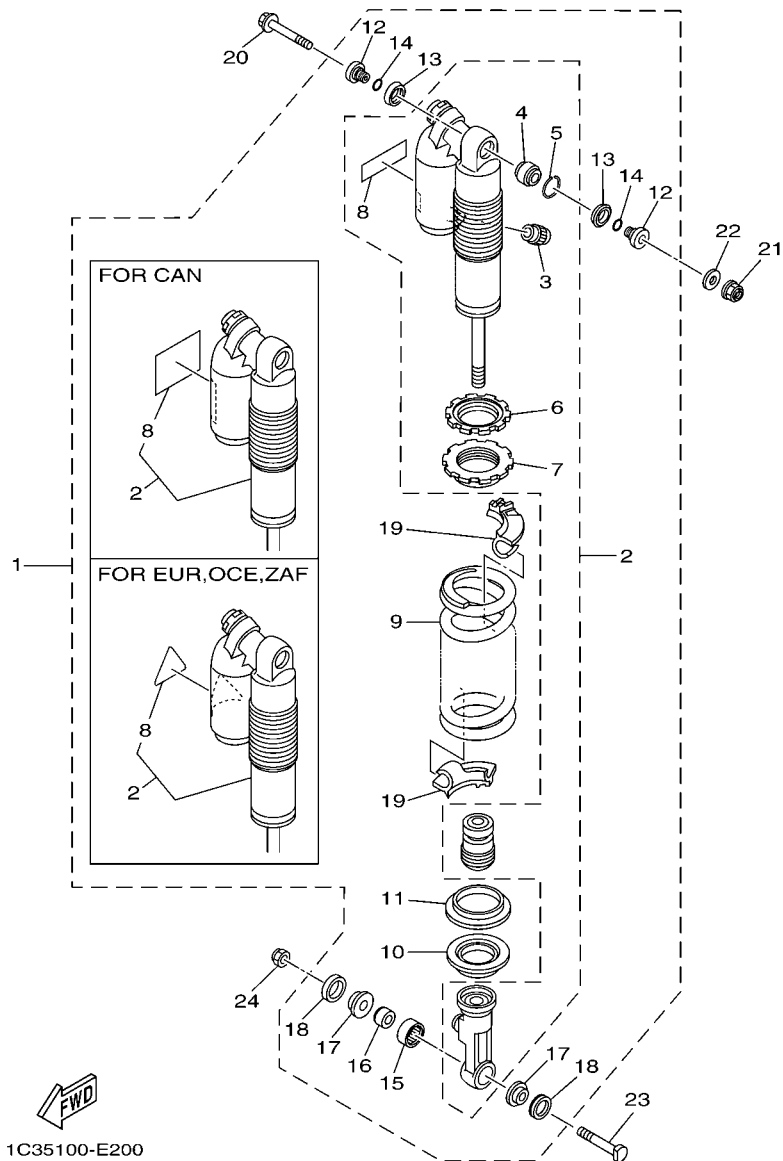

REF. NO.	PART NO.	DESCRIPTION	1P89	1P8A	1P8B	1P8C	REMARKS
1	1P8-22200-D0	SHOCK ABSORBER ASSY, REAR				1	
2	1P8-22201-A0	.DAMPER SUB ASSY	1		1	1	
3	509-23184-L0	..CAP, AIR VALVE	1	1	1	1	
4	4JX-22226-00	..BUSH, SHOCK ABSORBER LOWER	1	1	1	1	
5	5DH-23183-00	..CIRCLIP	1	1	1	1	
6	3SP-22234-00	..GUIDE, SPRING 3	1	1	1	1	
7	1C3-22213-L0	..SEAT, SPRING UPPER	1	1	1	1	
8	4AA-22259-40	..LABEL, WARNING				1	
9	1C3-22212-20	.SPRING (K=48N/MM)	1	1	1	1	
10	1C3-22214-50	.GUIDE, SPRING 1	1	1	1	1	
11	5MV-22224-00	.GUIDE, SPRING 2	1	1	1	1	
12	1C3-22253-50	.COLLAR, DISTANCE	2	2	2	2	
13	3JE-22475-00	.SEAL, DUST	2	2	2	2	
14	4EW-22474-00	.SEAL, RING	2	2	2	2	
15	5UN-22176-00	.BEARING	1	1	1	1	
16	5MV-22184-00	.BUSH	1	1	1	1	
17	1C3-22253-L0	.COLLAR, DISTANCE	2	2	2	2	
18	5NY-22475-00	.SEAL, DUST	2	2	2	2	
19	1C3-22565-00	.SPRING SEAT	2	2	2	2	

FIG. 20 REAR SUSPENSION

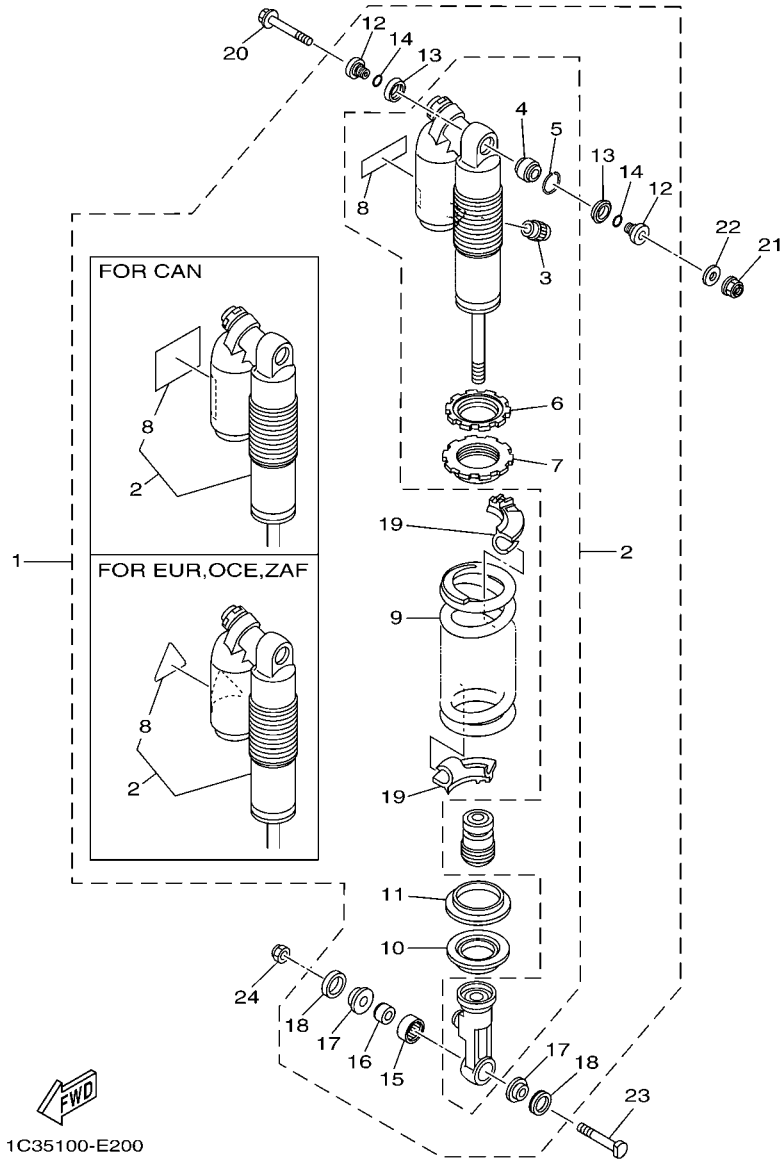

 1C35100-E200

REF. NO.	PART NO.	DESCRIPTION	1P89	1P8A	1P8B	1P8C	REMARKS
20	5XE-22242-00	BOLT 2	1	1	1	1	
21	95602-10200	NUT, U FLANGE	1	1	1	1	
22	92902-10200	WASHER	1	1	1	1	
23	5NY-22241-00	BOLT 1	1	1	1	1	
24	90185-10012	NUT, SELF-LOCKING	1	1	1	1	

FIG. 21 STEERING

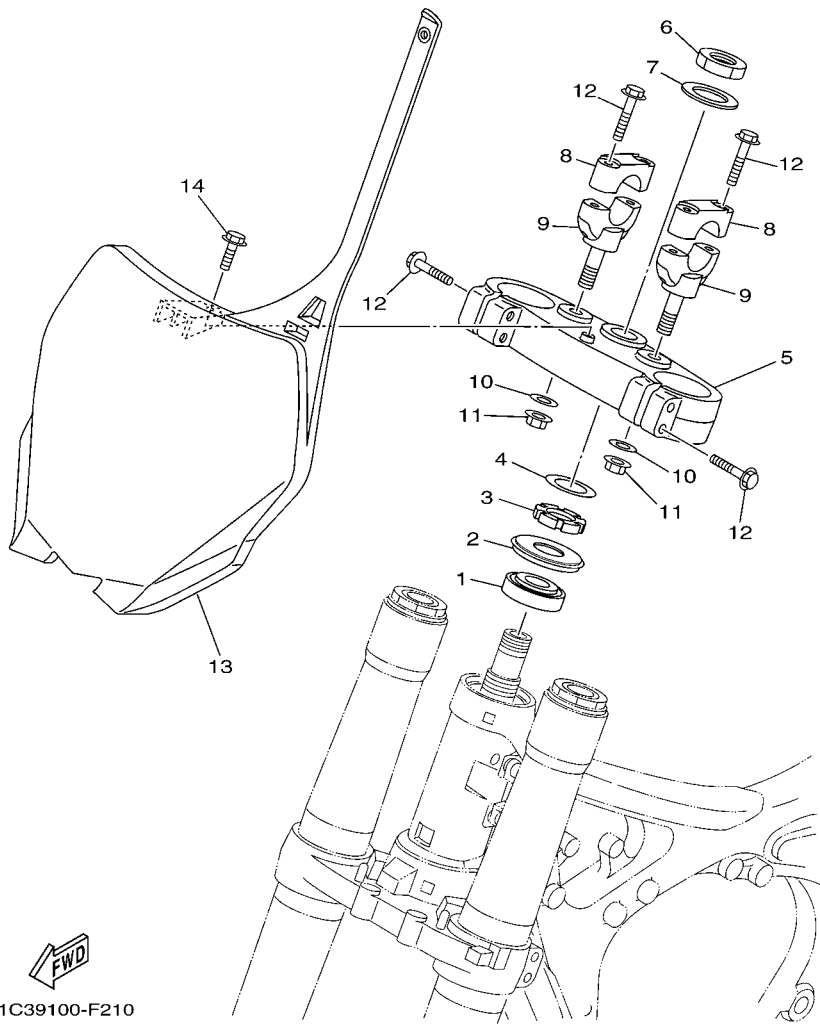

REF. NO.	PART NO.	DESCRIPTION	1P89	1P8A	1P8B	1P8C	REMARKS
1	93332-00068	BEARING	1	1	1	1	
2	4EW-23416-00	COVER, BALL RACE 2	1	1	1	1	
3	90179-28003	NUT	1	1	1	1	
4	90201-286K9	WASHER, PLATE	1	1	1	1	
5	1C3-23435-50	CROWN, HANDLE	1	1	1	1	
6	90170-24003	NUT	1	1	1	1	
7	90201-24016	WASHER, PLATE	1	1	1	1	
8	5XC-23441-90	HOLDER, HANDLE UPPER	2	2	2	2	
9	5XC-23442-90	HOLDER, HANDLE LOWER	2	2	2	2	
10	90201-12028	WASHER, PLATE	2	2	2	2	
11	95602-12200	NUT, SELF-LOCKING	2	2	2	2	
12	90105-08134	BOLT, FLANGE	8	8	8	8	
13	1C3-23485-51	PLATE, NUMBER	1	1	1	1	
14	90119-06146	BOLT, WITH WASHER	1	1	1	1	

1C39100-F210

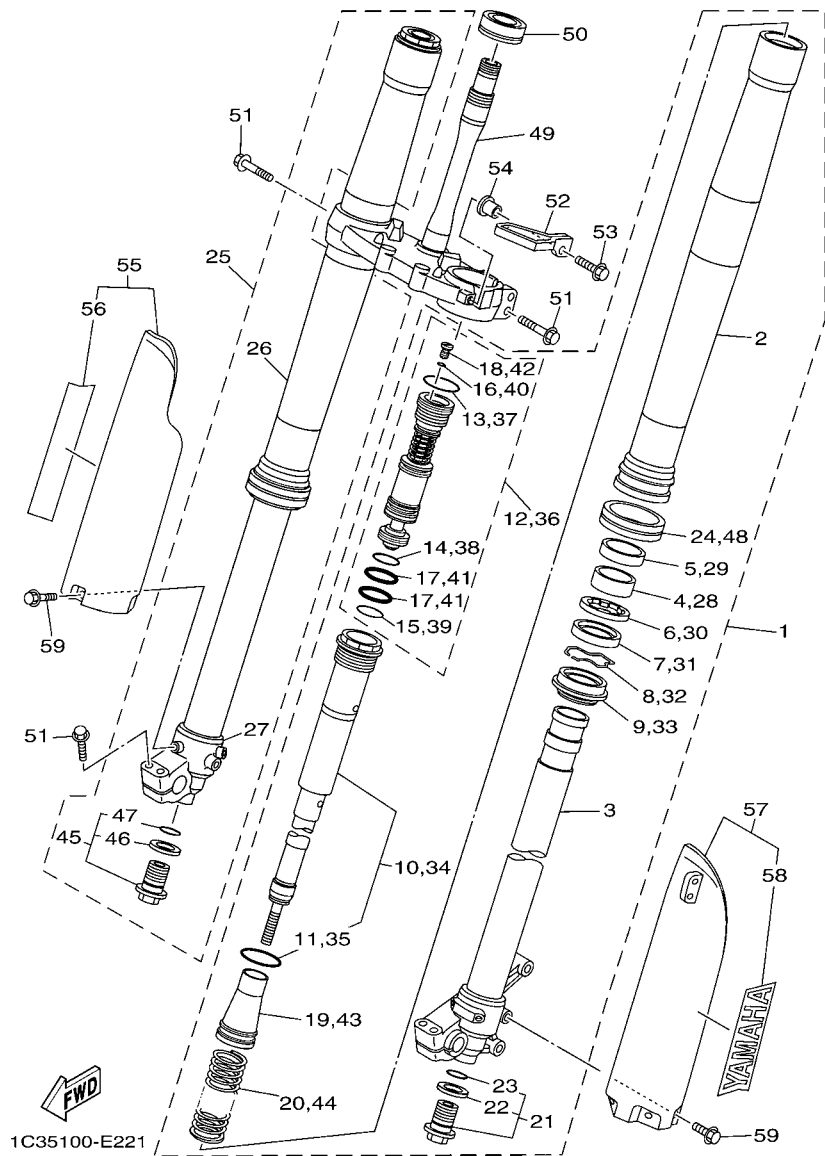

FIG. 22 FRONT FORK

REF. NO.	PART NO.	DESCRIPTION	1P89	1P8A	1P8B	1P8C	REMARKS
1	1P8-23102-A0	FRONT FORK ASSY (L.H)	1		1	1	
2	1C3-23136-N0	.TUBE, OUTER (RIGHT)	1	1	1	1	
3	5XC-23120-L0	.INNER TUBE COMP.2	1	1	1	1	
4	5XE-23171-L0	.PISTON, FRONT FORK	1	1	1	1	
5	5XE-23125-L0	.METAL, SLIDE 1	1	1	1	1	
6	5XE-23146-L0	.WASHER, OIL SEAL	1	1	1	1	
7	1C3-23145-M0	.OIL SEAL	1	1	1	1	
8	5XE-23153-L0	.RING, SNAP	1	1	1	1	
9	5XE-23144-L0	.SEAL, DUST	1	1	1	1	
10	1C3-23170-R0	.CYLINDER COMP., FRONT FORK	1		1	1	
11	1C3-23147-L0	..O-RING	1	1	1	1	
12	1C3-2316A-N0	.VALVE COMP.	1		1	1	
13	1C3-23188-L0	..O-RING	1	1	1	1	
14	1C3-23188-N0	..O-RING	1	1	1	1	
15	1C3-23188-P0	..O-RING	1	1	1	1	
16	1C3-23188-R0	..O-RING	1	1	1	1	
17	1AE-23147-00	..O-RING	2	2	2	2	
18	1C3-23190-L0	..AIR VALVE COMP.	1	1	1	1	
19	1C3-23142-L0	.SEAT, SPRING UPPER	1	1	1	1	
20	1P8-23141-M1	.SPRING, FRONT FORK(K=4.2N/MM)	1	1	1	1	
21	1C3-23111-L1	.BOLT, CAP	1	1	1	1	
22	2HH-23158-L0	..GASKET	1	1	1	1	
23	276-23114-00	..GASKET	1	1	1	1	
24	1C3-2314F-M0	.PROTECTOR GUIDE COMP., 1	1	1	1	1	

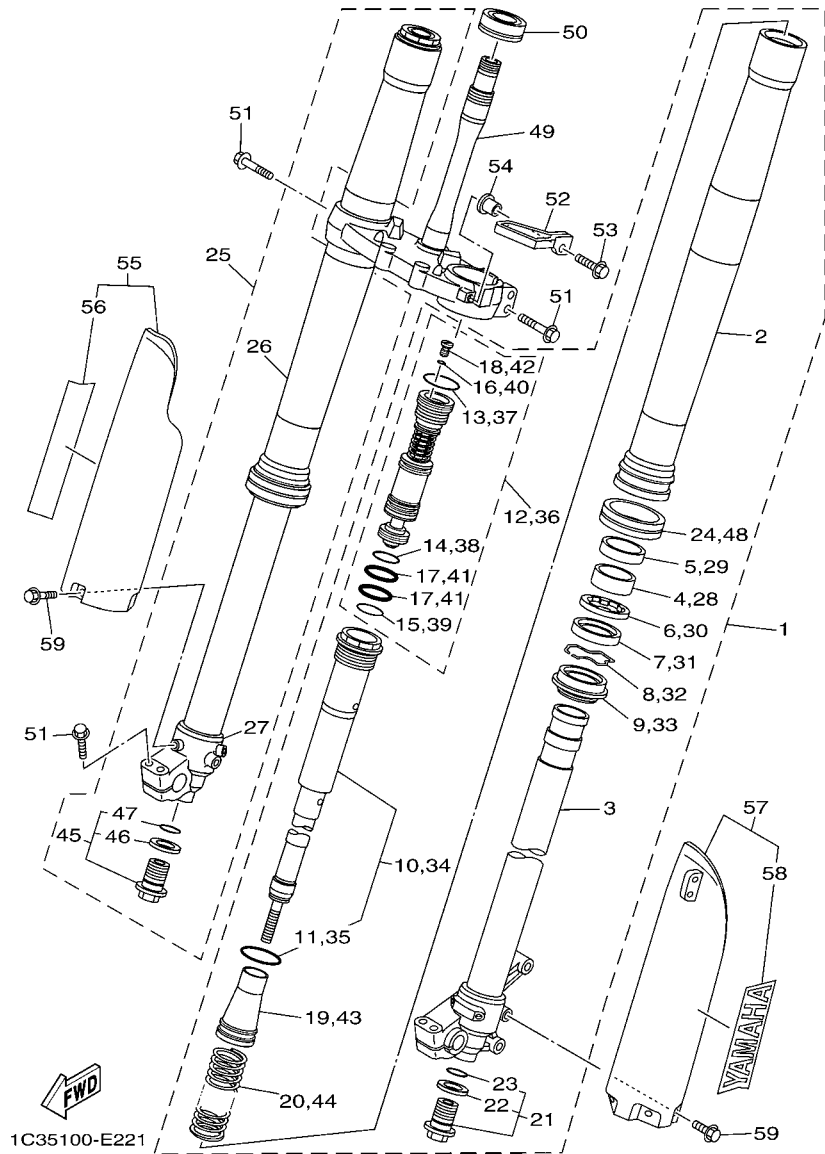

FIG. 22 FRONT FORK

REF. NO.	PART NO.	DESCRIPTION	1P89	1P8A	1P8B	1P8C	REMARKS
25	1P8-23103-A0	FRONT FORK ASSY (R.H)	1		1	1	
26	1C3-23136-N0	.TUBE, OUTER (RIGHT)	1	1	1	1	
27	5XC-23110-L0	.INNER TUBE COMP.1	1	1	1	1	
28	5XE-23171-L0	.PISTON, FRONT FORK	1	1	1	1	
29	5XE-23125-L0	.METAL, SLIDE 1	1	1	1	1	
30	5XE-23146-L0	.WASHER, OIL SEAL	1	1	1	1	
31	1C3-23145-M0	.OIL SEAL	1	1	1	1	
32	5XE-23153-L0	.RING, SNAP	1	1	1	1	
33	5XE-23144-L0	.SEAL, DUST	1	1	1	1	
34	1C3-23170-R0	.CYLINDER COMP., FRONT FORK	1		1	1	
35	1C3-23147-L0	..O-RING	1	1	1	1	
36	1C3-2316A-N0	.VALVE COMP.	1		1	1	
37	1C3-23188-L0	..O-RING	1	1	1	1	
38	1C3-23188-N0	..O-RING	1	1	1	1	
39	1C3-23188-P0	..O-RING	1	1	1	1	
40	1C3-23188-R0	..O-RING	1	1	1	1	
41	1AE-23147-00	..O-RING	2	2	2	2	
42	1C3-23190-L0	..AIR VALVE COMP.	1	1	1	1	
43	1C3-23142-L0	.SEAT, SPRING UPPER	1	1	1	1	
44	1P8-23141-M1	.SPRING, FRONT FORK(K=4.2N/MM)	1	1	1	1	
45	1C3-23111-L1	.BOLT, CAP	1	1	1	1	
46	2HH-23158-L0	..GASKET	1	1	1	1	
47	276-23114-00	..GASKET	1	1	1	1	
48	1C3-2314F-M0	.PROTECTOR GUIDE COMP., 1	1	1	1	1	

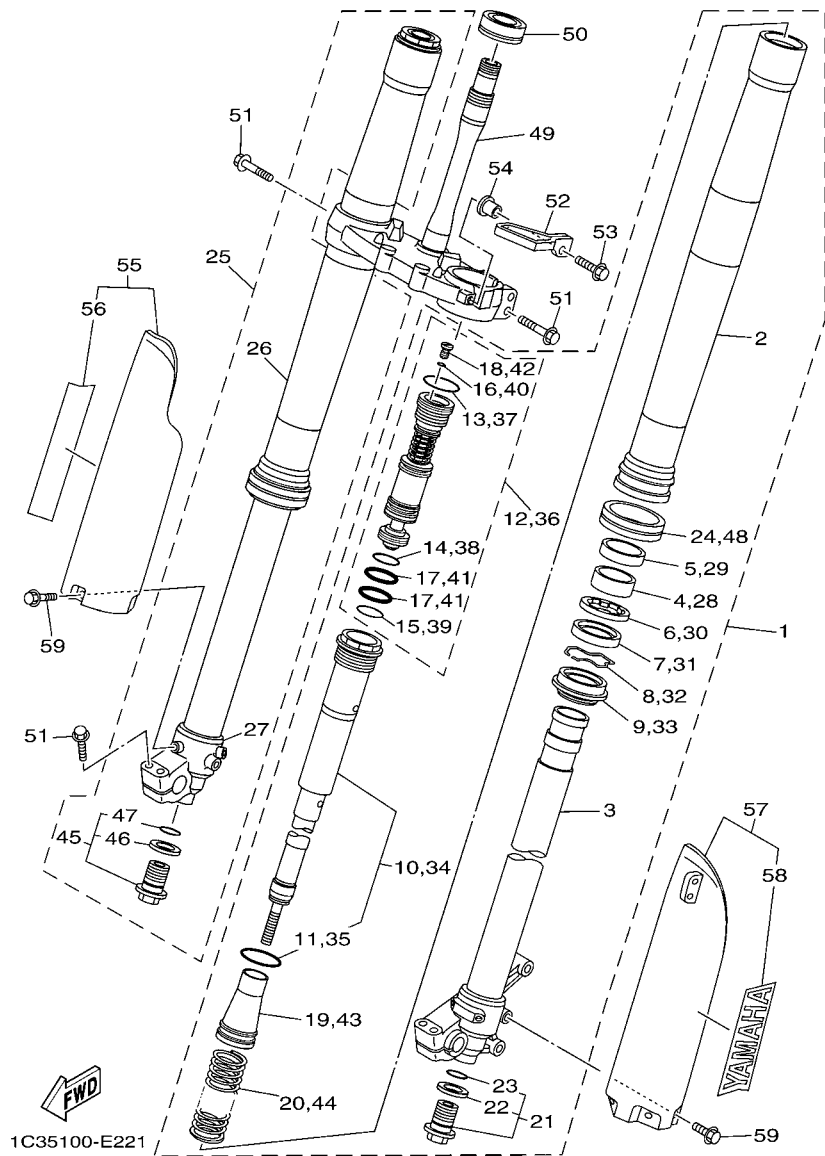
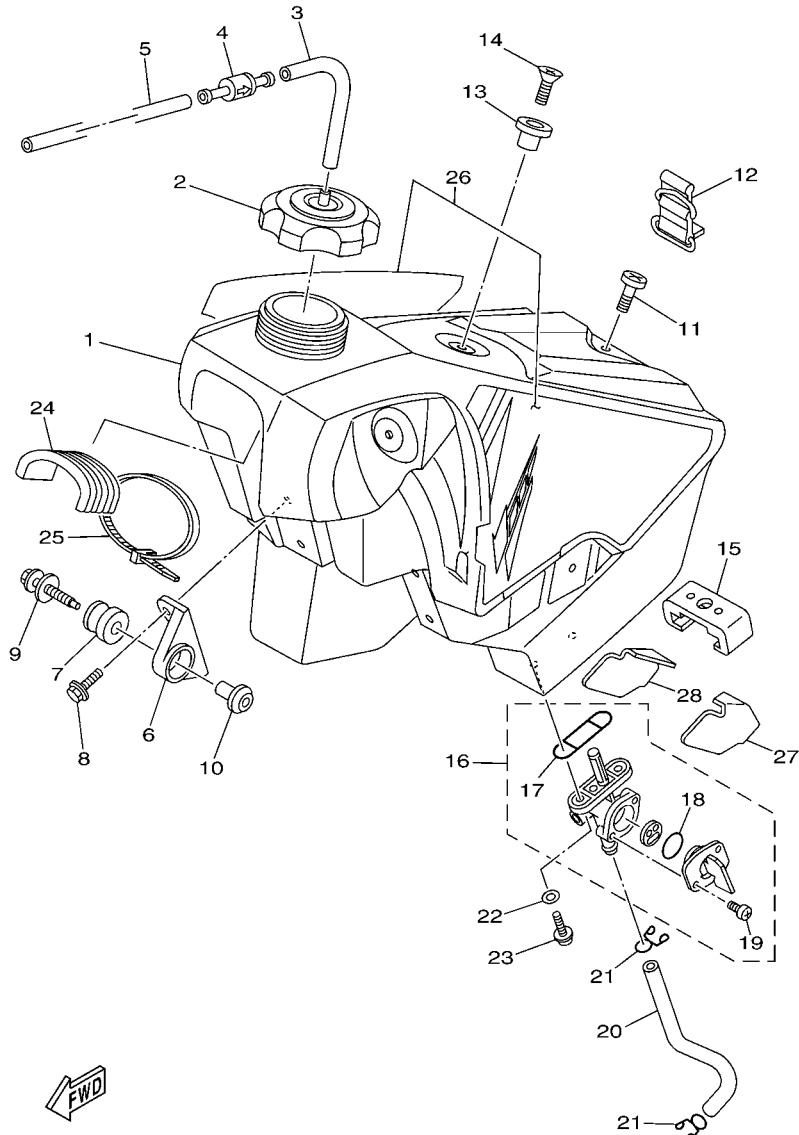

FIG. 22 FRONT FORK

REF. NO.	PART NO.	DESCRIPTION	1P89	1P8A	1P8B	1P8C	REMARKS
49	1P8-23340-M0	UNDER BRACKET COMP.	1	1	1	1	
50	93332-00081	BEARING	1	1	1	1	
51	90105-08134	BOLT, FLANGE	8	8	8	8	
52	5XE-23389-00	GUIDE, CABLE	1	1	1	1	
53	90105-06107	BOLT, FLANGE	1	1	1	1	
54	90387-06104	COLLAR	1	1	1	1	
55	1C3-2314J-10	PROTECTOR COMP., 2	1	1	1	1	
56	4XL-2153A-10	.EMBLEM, YAMAHA	1	1	1	1	
57	1C3-2314H-10	PROTECTOR COMP., 1	1	1	1	1	
58	4XL-2153A-10	.EMBLEM, YAMAHA	1	1	1	1	
59	3SP-23356-L0	BOLT 2	6	6	6	6	

FIG. 23 FUEL TANK



1C39100-F230

REF. NO.	PART NO.	DESCRIPTION	1P89	1P8A	1P8B	1P8C	REMARKS
1	1C3-24110-90	FUEL TANK COMP.	1	1	1	1	
2	5NY-24610-00	CAP ASSY	1	1	1	1	
3	90445-09220	HOSE (L30)	1	1	1	1	
4	3XJ-24380-00	PIPE JOINT ASSY	1	1	1	1	
5	90445-09251	HOSE (L350)	1	1	1	1	
6	5XE-24144-00	HOLDER, DAMPER	2	2	2	2	
7	90480-18549	GROMMET	2	2	2	2	
8	90105-06107	BOLT, FLANGE	4	4	4	4	
9	5XE-24176-10	BOLT 1	2	2	2	2	
10	5NY-24186-00	WASHER, SPECIAL	2	2	2	2	
11	98902-06025	SCREW, BIND	1	1	1	1	
12	3SP-24173-00	BAND, TANK FITTING 1	1	1	1	1	
13	4EW-2412F-00	BRACKET, SEAT	1	1	1	1	
14	98702-06025	SCREW, FLAT HEAD	1	1	1	1	
15	1C3-24181-00	DAMPER, LOCATING 1	1	1	1	1	
16	3JD-24500-10	FUEL COCK ASSY 1	1	1	1	1	
17	4X8-24512-00	.O-RING	1	1	1	1	
18	3AJ-24534-01	.SEAL, COCK	1	1	1	1	
19	98507-03008	.SCREW, PAN HEAD	2	2	2	2	
20	90445-111J0	HOSE (L145)	1	1	1	1	
21	90467-100A1	CLIP	2	2	2	2	
22	90202-05193	WASHER, PLATE	2	2	2	2	
23	90149-06108	SCREW	2	2	2	2	
24	1P8-24182-00	DAMPER, LOCATING 2	1	1	1	1	
25	90465-13275	CLAMP	1	1	1	1	
26	1C3-24240-20	GRAPHIC SET	1	1	1	1	
27	1C3-24183-00	DAMPER, LOCATING 3	1	1	1	1	

FIG. 23 FUEL TANK

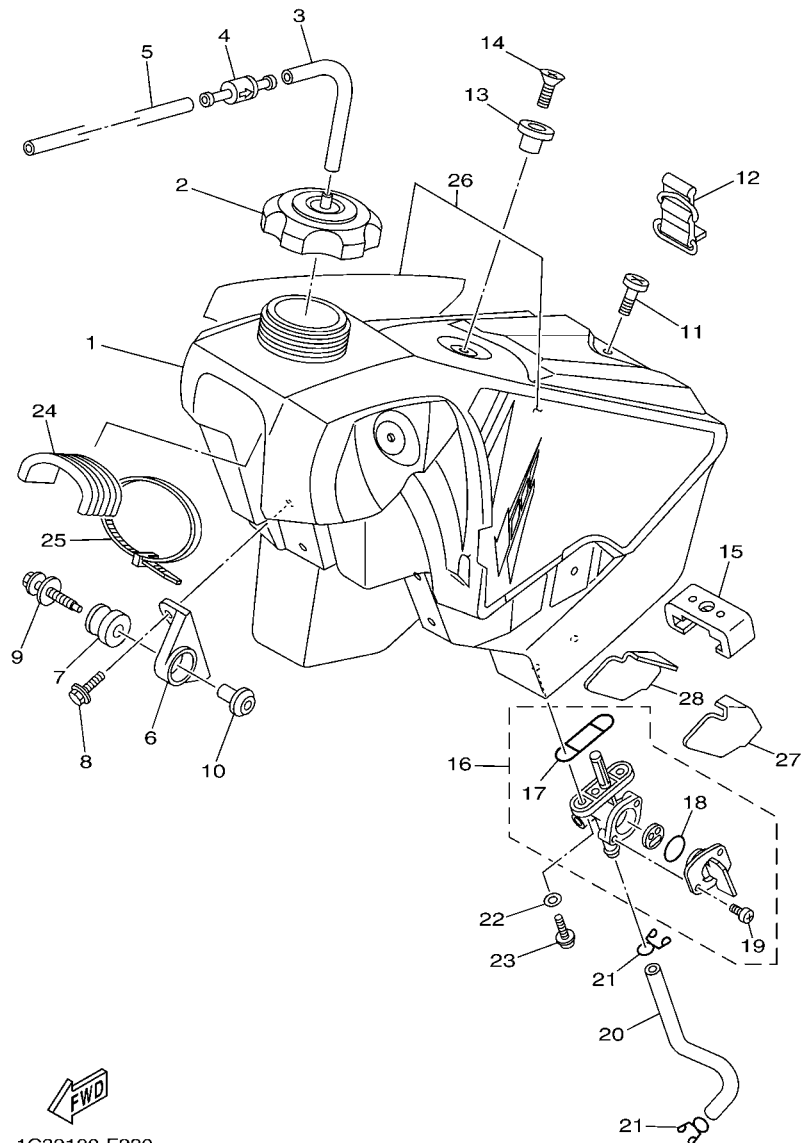

1C39100-F230

REF. NO.	PART NO.	DESCRIPTION	1P89	1P8A	1P8B	1P8C	REMARKS
28	1C3-24184-00	DAMPER, LOCATING 4	1	1	1	1	

FIG. 24 SEAT

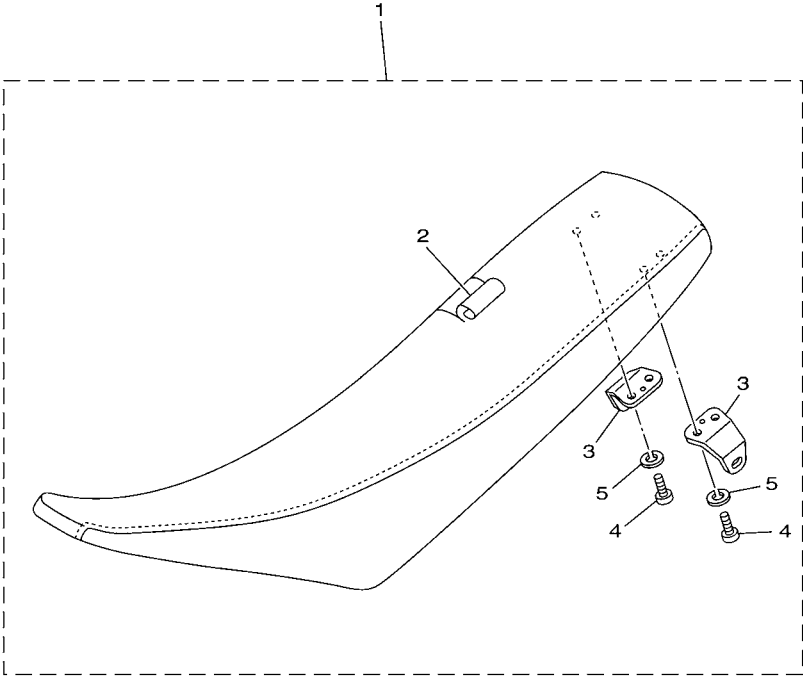

REF. NO.	PART NO.	DESCRIPTION	1P89	1P8A	1P8B	1P8C	REMARKS
1	1C3-24770-51	SEMI-DOUBLE SEAT ASSY	1	1	1	1	
2	1C3-2470F-50	.SEAT COVER COMP.	1	1	1	1	
3	5NY-24728-10	.BRACKET, SEAT	2	2	2	2	
4	97002-06012	.BOLT	4	4	4	4	
5	92902-06100	.WASHER, SPRING	4	4	4	4	
<hr/>							
<hr/>							
<hr/>							
<hr/>							
<hr/>							
<hr/>							
<hr/>							
<hr/>							
<hr/>							
<hr/>							
<hr/>							
<hr/>							

 5NY1100-A241

FIG. 25 FRONT WHEEL

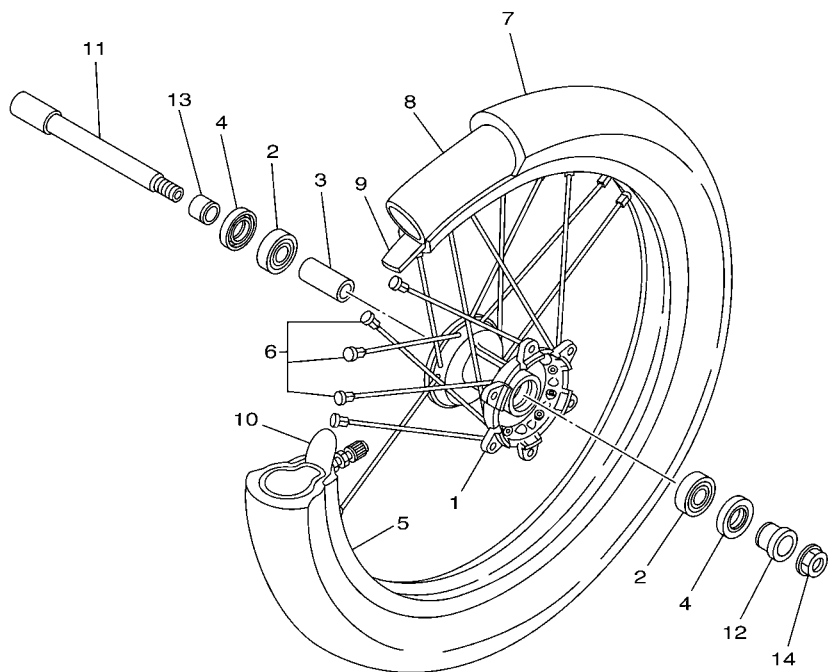

REF. NO.	PART NO.	DESCRIPTION	1P89	1P8A	1P8B	1P8C	REMARKS
1	5NY-25111-00	HUB, FRONT	1	1	1	1	
2	93306-90409	BEARING	2	2	2	2	
3	5NY-25117-00	SPACER, BEARING	1	1	1	1	
4	93102-26468	OIL SEAL	2	2	2	2	
5	94416-21018	RIM (1.60-21)	1	1	1	1	
6	5NY-25104-00	SPOKE SET, FRONT	1	1	1	1	
7	L.M.	TIRE (80/100-21 51M D739FA)				1	
8	L.M.	TUBE (80/100-21 M/C TR4)				1	
9	94309-21161	BAND, RIM (1.60-21)	1	1	1	1	DUNLOP
10	5SF-25394-00	SPACER, BEAD	1	1	1	1	
11	1C3-25181-10	AXLE, WHEEL	1	1	1	1	
12	5NY-25183-00	COLLAR, WHEEL	1	1	1	1	
13	5NY-25186-00	COLLAR, WHEEL	1	1	1	1	
14	90179-16011	NUT	1	1	1	1	



1C31100-D250

D11

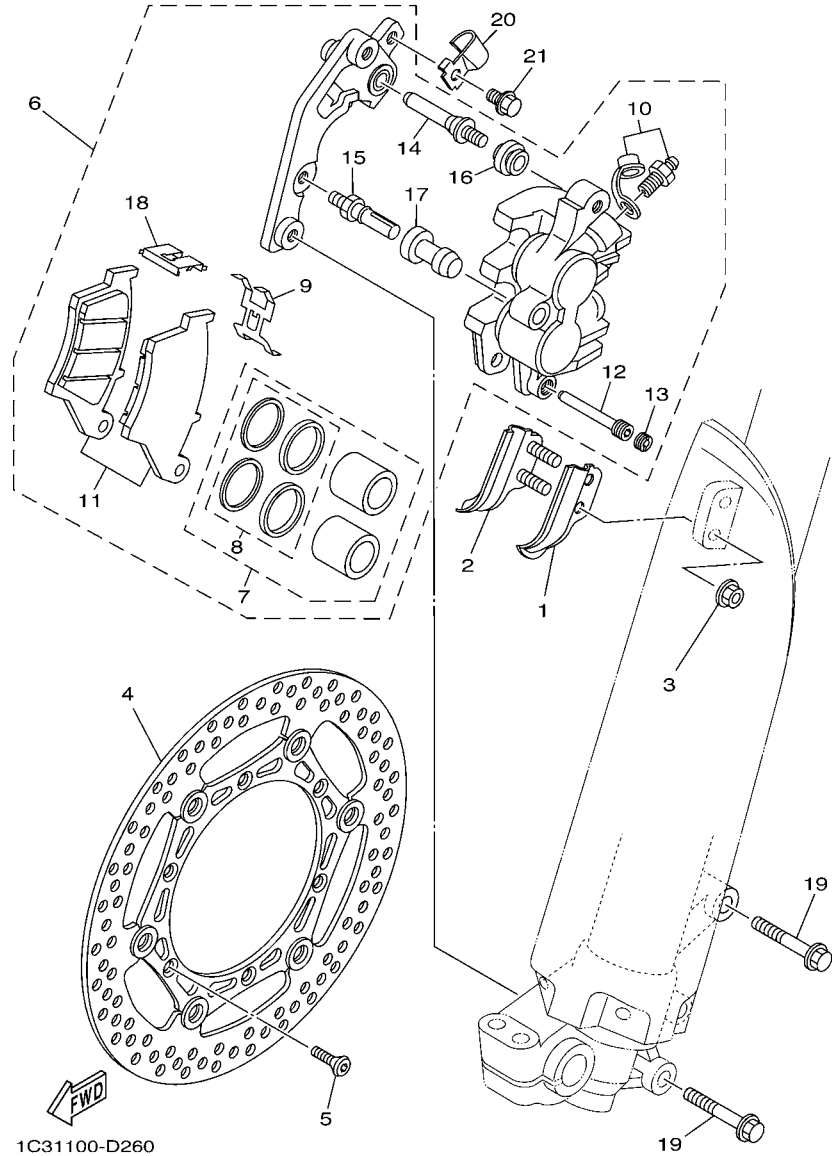
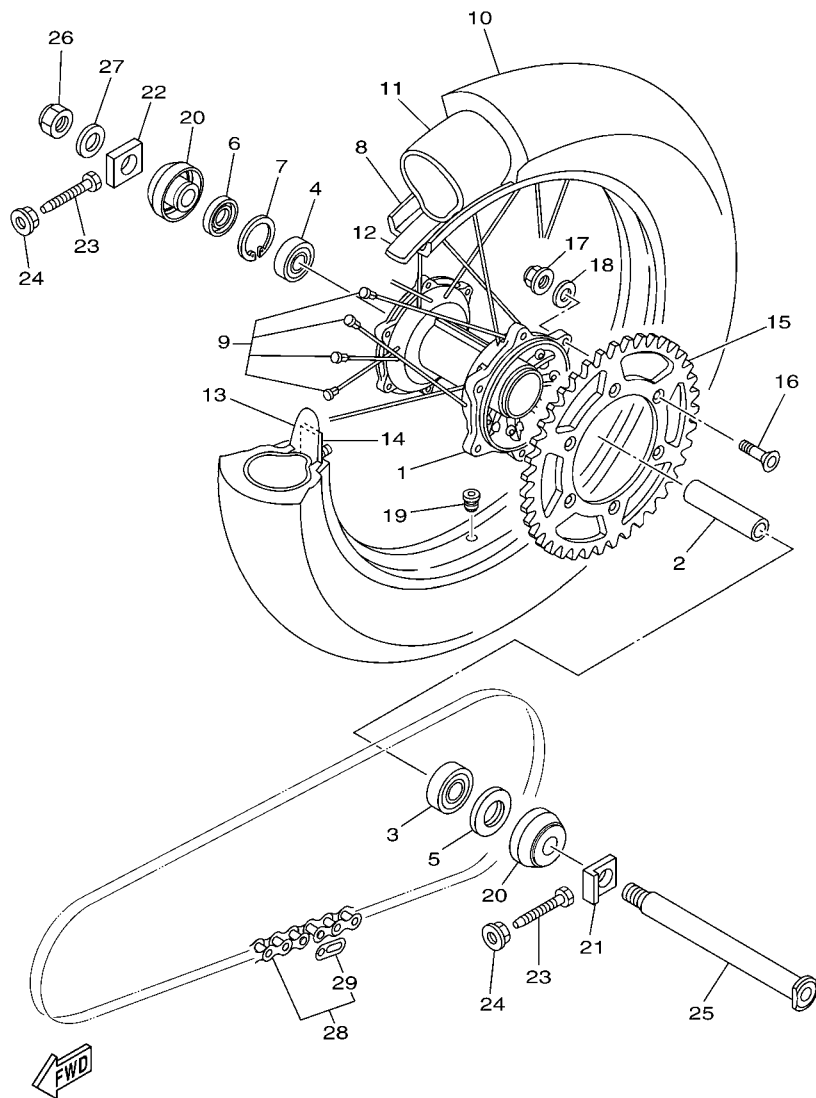

FIG. 26 FRONT BRAKE CALIPER

REF. NO.	PART NO.	DESCRIPTION	1P89	1P8A	1P8B	1P8C	REMARKS
1	1C3-23466-50	CLAMP	1	1	1	1	
2	1C3-23467-50	CLAMP	1	1	1	1	
3	95702-06500	NUT, FLANGE	2	2	2	2	
4	5MV-2581T-00	DISK BRAKE ASSY	1	1	1	1	
5	90149-06327	SCREW	6	6	6	6	
6	1C3-2580T-00	CALIPER ASSY (LEFT)	1	1	1	1	
7	5UN-W0057-00	.PISTON ASSY, CALIPER	1	1	1	1	
8	3JD-W0047-00	..CALIPER SEAL KIT	1	1	1	1	
9	5DH-25919-00	.SUPPORT, PAD	1	1	1	1	
10	1UY-W0048-50	.BLEED SCREW KIT	1	1	1	1	
11	5MV-W0045-01	.BRAKE PAD KIT	1	1	1	1	
12	5DH-25933-00	.PIN, PAD	1	1	1	1	
13	5DH-25916-00	.PLUG	1	1	1	1	
14	3SP-25926-51	.BOLT	1	1	1	1	
15	3SP-25914-51	.PIN, SLIDE	1	1	1	1	
16	3JD-25917-00	.BOOT, CALIPER	1	1	1	1	
17	1UY-25937-51	.BOOT 2	1	1	1	1	
18	5DH-25849-00	.RETAINER, CALIPER	1	1	1	1	
19	90105-08137	BOLT, FLANGE	2	2	2	2	
20	1C3-25875-50	HOLDER, BRAKE HOSE 1	1	1	1	1	
21	90105-06105	BOLT, FLANGE	1	1	1	1	



1C35100-E270

FIG. 27 REAR WHEEL

REF. NO.	PART NO.	DESCRIPTION	1P89	1P8A	1P8B	1P8C	REMARKS
1	5ET-25311-00	HUB, REAR	1	1	1	1	
2	5ET-25317-00	SPACER, BEARING	1	1	1	1	
3	93306-27212	BEARING	1	1	1	1	
4	93306-07202	BEARING	1	1	1	1	
5	93106-30001	OIL SEAL	1	1	1	1	
6	93106-30045	OIL SEAL	1	1	1	1	
7	99009-45500	CIRCLIP	1	1	1	1	
8	94421-19003	RIM (2.15-19)	1	1	1	1	
9	5HD-25304-00	SPOKE SET, REAR	1	1	1	1	
10	L.M.	TIRE (110/90-19 62M D756)				1	
11	L.M.	TUBE (110/90-19 M/C TR4)				1	
12	94311-19155	BAND, RIM (2.15-19)	1	1		1	
13	3JE-25394-00	SPACER, BEAD	1	1	1	1	
14	4XM-25364-00	DAMPER	1	1	1	1	
15	1C3-25450-00	SPROCKET, DRIVEN (50T)	1	1	1	1	STD
	1C3-25447-00	SPROCKET, DRIVEN (47T)	1	1	1	1	AP
	1C3-25448-00	SPROCKET, DRIVEN (48T)	1	1	1	1	AP
	1C3-25449-00	SPROCKET, DRIVEN (49T)	1	1	1	1	AP
	1C3-25451-00	SPROCKET, DRIVEN (51T)	1	1	1	1	AP
	1C3-25452-00	SPROCKET, DRIVEN (52T)	1	1	1	1	AP
16	90109-08078	BOLT	6	6	6	6	
17	90185-08008	NUT, SELF-LOCKING	6	6	6	6	
18	90201-08048	WASHER, PLATE	6	6	6	6	

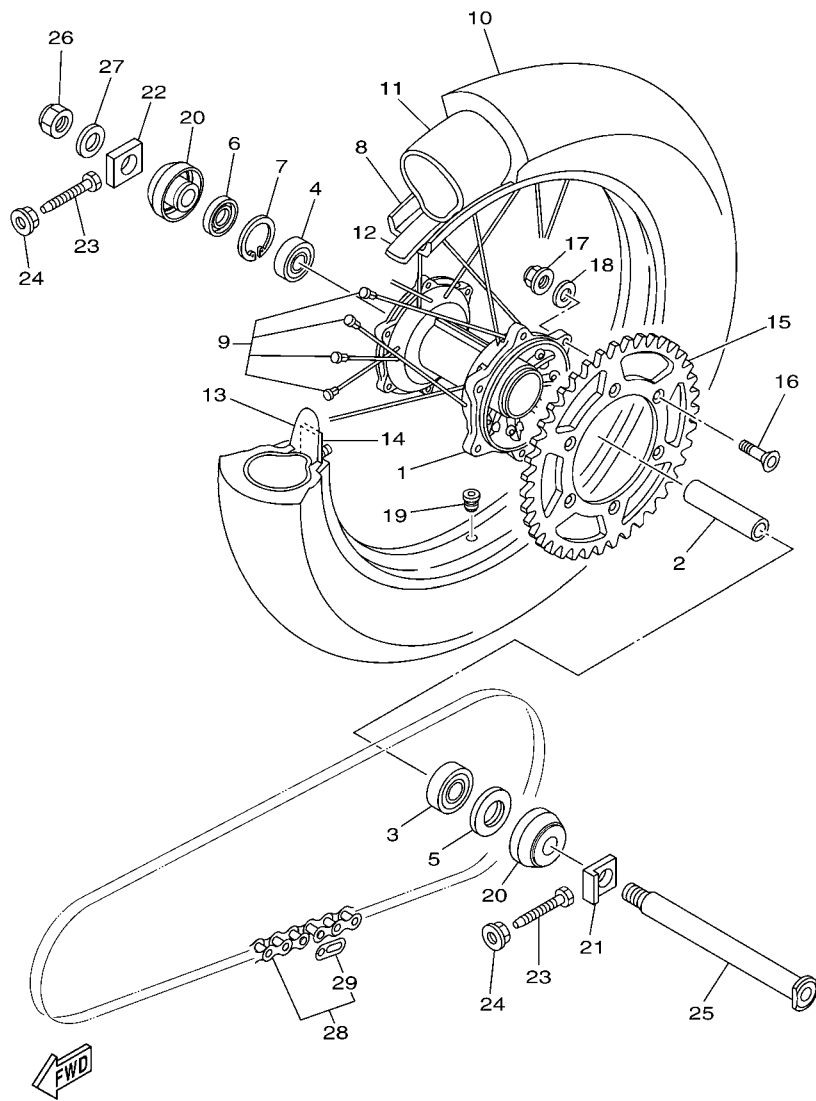

1C35100-E270

FIG. 27 REAR WHEEL

REF. NO.	PART NO.	DESCRIPTION	1P89	1P8A	1P8B	1P8C	REMARKS
19	90480-08608	GROMMET	1	1	1	1	
20	5TJ-2530S-80	COLLAR ASSY	2	2	2	2	
21	1C3-25388-50	PULLER, CHAIN 1	1	1	1	1	
22	1C3-25389-00	PULLER, CHAIN 2	1	1	1	1	
23	90101-08006	BOLT	2	2	2	2	
24	90179-08674	NUT	2	2	2	2	
25	1C3-25381-90	AXLE, WHEEL	1	1	1	1	
26	90185-20002	NUT, SELF-LOCKING	1	1	1	1	
27	90201-20020	WASHER, PLATE	1	1	1	1	
28	9Y581-92113	CHAIN (DID 520D 114L)	1	1	1	1	
29	94681-68001	.JOINT,CHAIN (DID 520DM-RJ)	1	1	1	1	

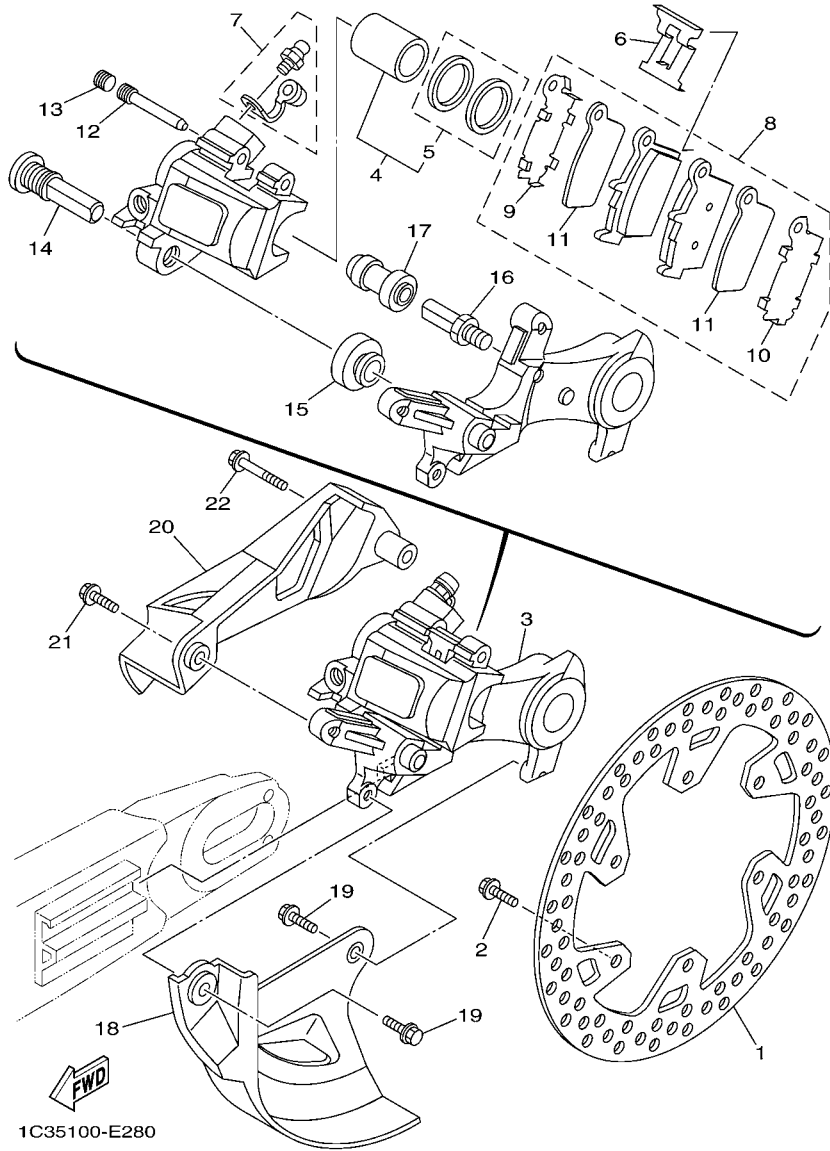
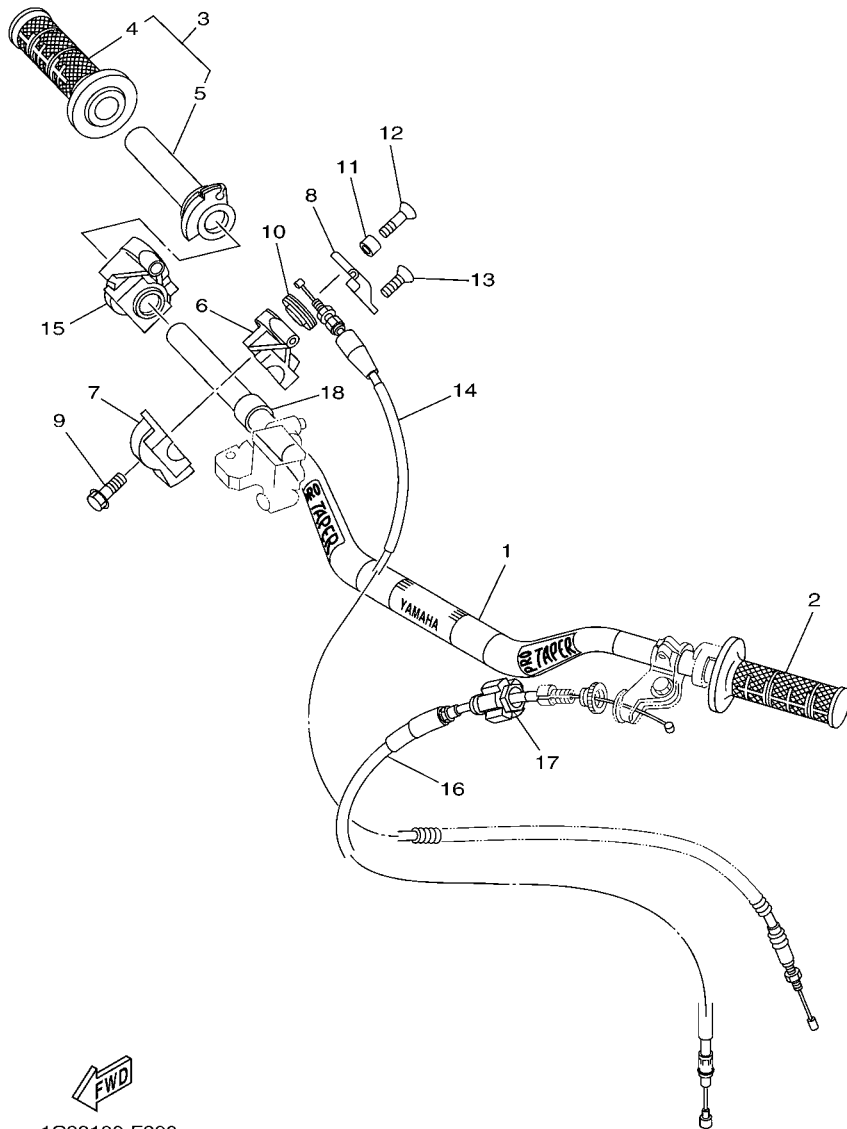

FIG. 28 REAR BRAKE CALIPER

REF. NO.	PART NO.	DESCRIPTION	1P89	1P8A	1P8B	1P8C	REMARKS
1	5NY-2582W-00	DISK, REAR BRAKE 2	1	1	1	1	
2	90105-06108	BOLT, FLANGE	6	6	6	6	
3	1C3-2580W-60	CALIPER ASSY, REAR 2	1	1	1	1	
4	5UN-W0057-50	.PISTON ASSY, CALIPER	1	1	1	1	
5	5UN-W0047-50	..CALIPER SEAL KIT	1	1	1	1	
6	5DH-25919-50	..SUPPORT, PAD	1	1	1	1	
7	1UY-W0048-50	.BLEED SCREW KIT	1	1	1	1	
8	1C3-W0046-10	.BRAKE PAD KIT 2	1	1	1	1	
9	5UN-25828-60	..SHIM, CALIPER	1	1	1	1	
10	5UN-25827-60	..SHIM, CALIPER	1	1	1	1	
11	5UN-22898-60	..INSULATOR, HEAT	2	2	2	2	
12	8CR-25924-00	.PIN, PAD	1	1	1	1	
13	5DH-25916-00	.PLUG	1	1	1	1	
14	5DH-25914-50	.PIN, SLIDE	1	1	1	1	
15	3JD-25917-00	.BOOT, CALIPER	1	1	1	1	
16	5UN-25914-00	.PIN, SLIDE	1	1	1	1	
17	1UY-25937-51	.BOOT 2	1	1	1	1	
18	1C3-25718-50	PROTECTOR, DISK BRAKE	1	1	1	1	
19	90105-06110	BOLT, FLANGE	2	2	2	2	
20	1C3-27491-50	PROTECTOR	1	1	1	1	
21	90105-06107	BOLT, FLANGE	1	1	1	1	
22	90105-06111	BOLT, FLANGE	1	1	1	1	



1C39100-F290

FIG. 29 STEERING HANDLE & CABLE

REF. NO.	PART NO.	DESCRIPTION	1P89	1P8A	1P8B	1P8C	REMARKS
1	1C3-26111-90	HANDLEBAR	1	1	1	1	
2	4GY-26241-00	GRIP	1	1	1	1	
3	4XM-26240-00	GRIP ASSY	1	1	1	1	
4	4GY-26242-00	.GRIP (RIGHT)	1	1	1	1	
5	4XM-26243-00	.TUBE, THROTTLE GUIDE	1	1	1	1	
6	1C3-26281-90	CAP, GRIP UPPER	1	1	1	1	
7	1C3-26282-90	CAP, GRIP LOWER	1	1	1	1	
8	1C3-2628H-90	CAP, WIRE	1	1	1	1	
9	90105-06112	BOLT, FLANGE	2	2	2	2	
10	1C3-26273-90	ROTOR	1	1	1	1	
11	90387-04003	COLLAR	1	1	1	1	
12	98680-04510	SCREW, OVAL HEAD	1	1	1	1	
13	98680-04516	SCREW, OVAL HEAD	1	1	1	1	
14	1P8-26311-90	CABLE, THROTTLE 1	1	1	1	1	
15	4SS-26287-01	COVER, CAP GRIP	1	1	1	1	
16	1P8-26335-90	CABLE, CLUTCH	1	1	1	1	
17	1C3-26342-50	BOOT, CABLE	1	1	1	1	
18	90387-227H7	COLLAR	1	1	1	1	

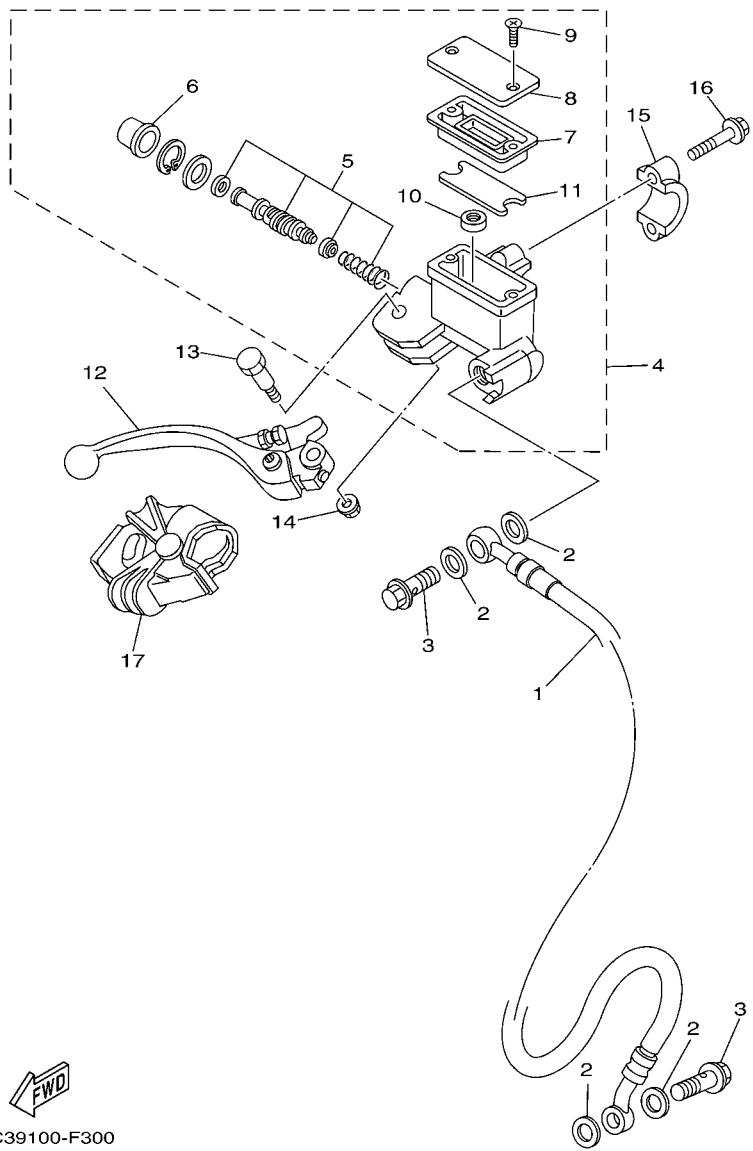



1C39100-F300

FIG. 30 FRONT MASTER CYLINDER

REF. NO.	PART NO.	DESCRIPTION	1P89	1P8A	1P8B	1P8C	REMARKS
1	1C3-25872-90	HOSE, BRAKE 1	1	1	1	1	
2	90430-10005	GASKET	4	4	4	4	
3	90401-10172	BOLT, UNION	2	2	2	2	
4	5XE-W2587-10	MASTER CYLINDER SUB ASSY	1	1	1	1	
5	5NY-W0041-00	.CYLINDER KIT, MASTER	1	1	1	1	
6	5NY-25868-00	.BOOT, MASTER CYLINDER	1	1	1	1	
7	5XE-25854-00	.DIAPHRAGM, RESERVOIR	1	1	1	1	
8	5MV-25852-01	.CAP, RESERVOIR	1	1	1	1	
9	98706-04012	.SCREW, FLAT HEAD	2	2	2	2	
10	5CG-25715-00	.SEPARATOR ASSY	1	1	1	1	
11	5XE-25853-00	.FLOAT, RESERVOIR	1	1	1	1	
12	1C3-83922-50	LEVER 2	1	1	1	1	
13	5MV-2589F-00	BOLT, LEVER	1	1	1	1	
14	95701-06500	NUT, FLANGE	1	1	1	1	
15	5MV-25867-00	BRACKET, MASTER CYLINDER	1	1	1	1	
16	5MV-25833-00	BOLT, FITTING	2	2	2	2	
17	5NY-26372-00	COVER, HANDLE LEVER 1	1	1	1	1	

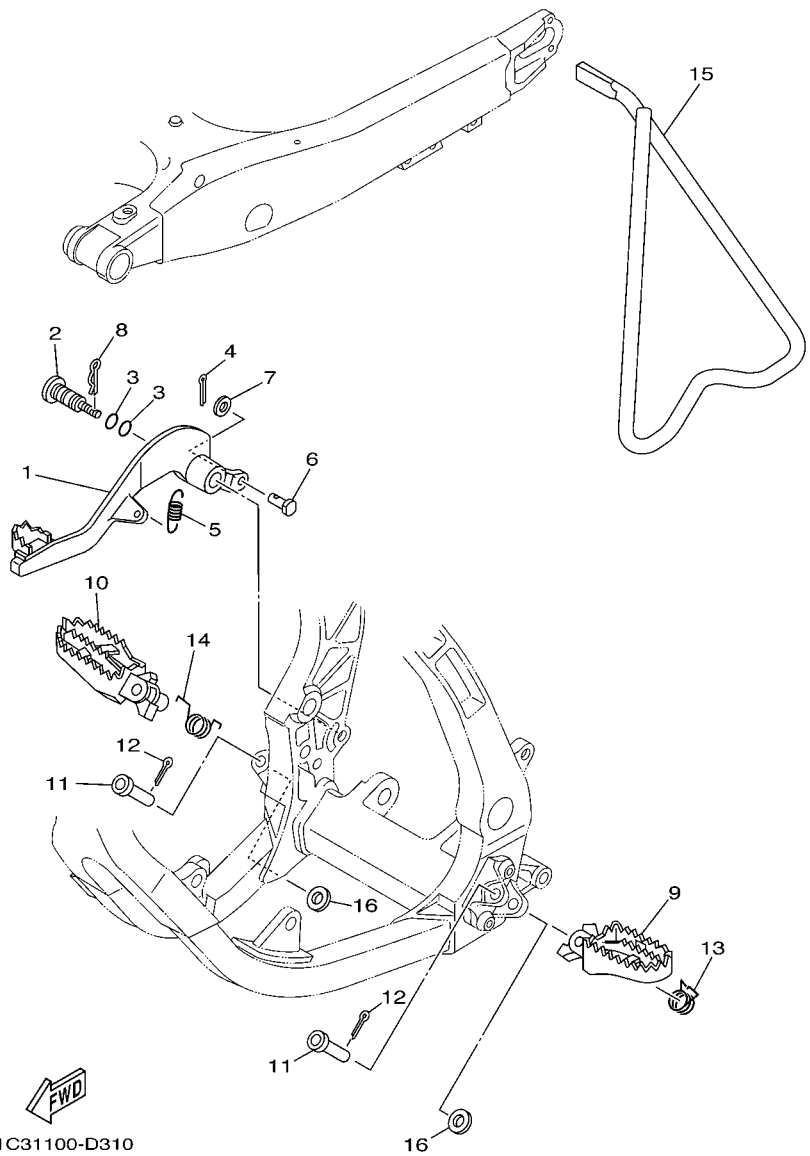
FIG. 31 STAND & FOOTREST



REF. NO.	PART NO.	DESCRIPTION	1P89	1P8A	1P8B	1P8C	REMARKS
1	4XM-27200-10	PEDAL, BRAKE	1	1	1	1	
2	1C3-27217-10	BOLT	1	1	1	1	
3	93210-11073	O-RING	2	2	2	2	
4	91402-20012	PIN, COTTER	1	1	1	1	
5	90506-16007	SPRING, TENSION	1	1	1	1	
6	90240-08120	PIN, CLEVIS	1	1	1	1	
7	90201-08044	WASHER, PLATE	1	1	1	1	
8	90468-16001	CLIP	1	1	1	1	
9	5XE-27411-01	FOOTREST 1	1	1	1	1	
10	5XE-27421-01	FOOTREST 2	1	1	1	1	
11	90240-10004	PIN, CLEVIS	2	2	2	2	
12	91402-25015	PIN, COTTER	2	2	2	2	
13	90508-28015	SPRING, TORSION	1	1	1	1	
14	90508-28018	SPRING, TORSION	1	1	1	1	
15	1C3-27311-00	STAND, SIDE	1	1	1	1	
16	90201-10032	WASHER, PLATE	2	2	2	2	

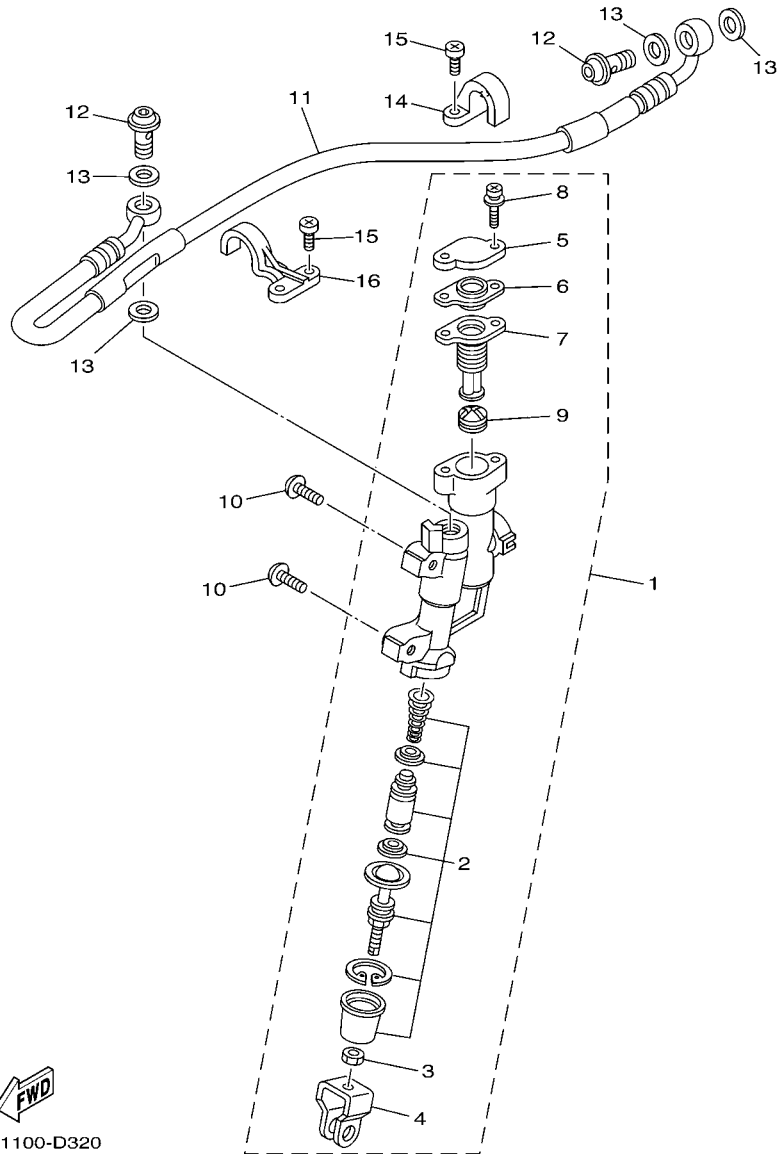

1C31100-D320

FIG. 32 REAR MASTER CYLINDER

REF. NO.	PART NO.	DESCRIPTION	1P89	1P8A	1P8B	1P8C	REMARKS
1	1C3-2583V-00	RR. MASTER CYLINDER ASSY.	1	1	1	1	
2	5UN-W0042-50	.CYLINDER KIT, MASTER	1	1	1	1	
3	5UN-27218-00	.NUT	1	1	1	1	
4	5UN-27222-00	.JOINT	1	1	1	1	
5	5UN-25852-50	.CAP, RESERVOIR	1	1	1	1	
6	5UN-2585B-00	.PLATE, DIAPHRAGM	1	1	1	1	
7	5UN-25854-00	.DIAPHRAGM, RESERVOIR	1	1	1	1	
8	5UN-27217-00	.BOLT	2	2	2	2	
9	5CG-25715-00	.SEPARATOR ASSY	1	1	1	1	
10	90111-06059	BOLT,HEX. SOCKET BUTTON	2	2	2	2	
11	1C3-25873-00	HOSE, BRAKE 2	1	1	1	1	
12	90401-10172	BOLT, UNION	2	2	2	2	
13	90430-10005	GASKET	4	4	4	4	
14	1C3-25886-50	HOLDER, BRAKE HOSE	1	1	1	1	
15	98502-05010	SCREW, PAN HEAD	4	4	4	4	
16	1C3-25876-50	HOLDER, BRAKE HOSE 2	1	1	1	1	

FIG. 33 GENERATOR

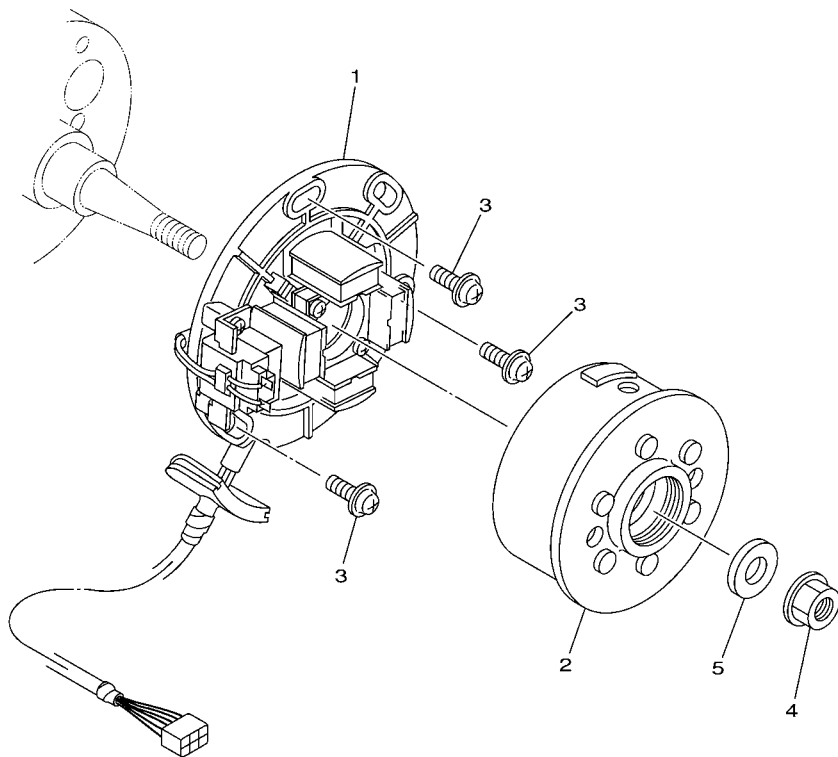

REF. NO.	PART NO.	DESCRIPTION	1P89	1P8A	1P8B	1P8C	REMARKS
1	5CU-85560-20	BASE ASSY	1	1	1	1	
2	5UP-85550-01	ROTOR ASSY	1	1	1	1	
3	90149-06108	SCREW	3	3	3	3	
4	90179-12004	NUT	1	1	1	1	
5	90201-12038	WASHER, PLATE	1	1	1	1	

 5NX1100-A330

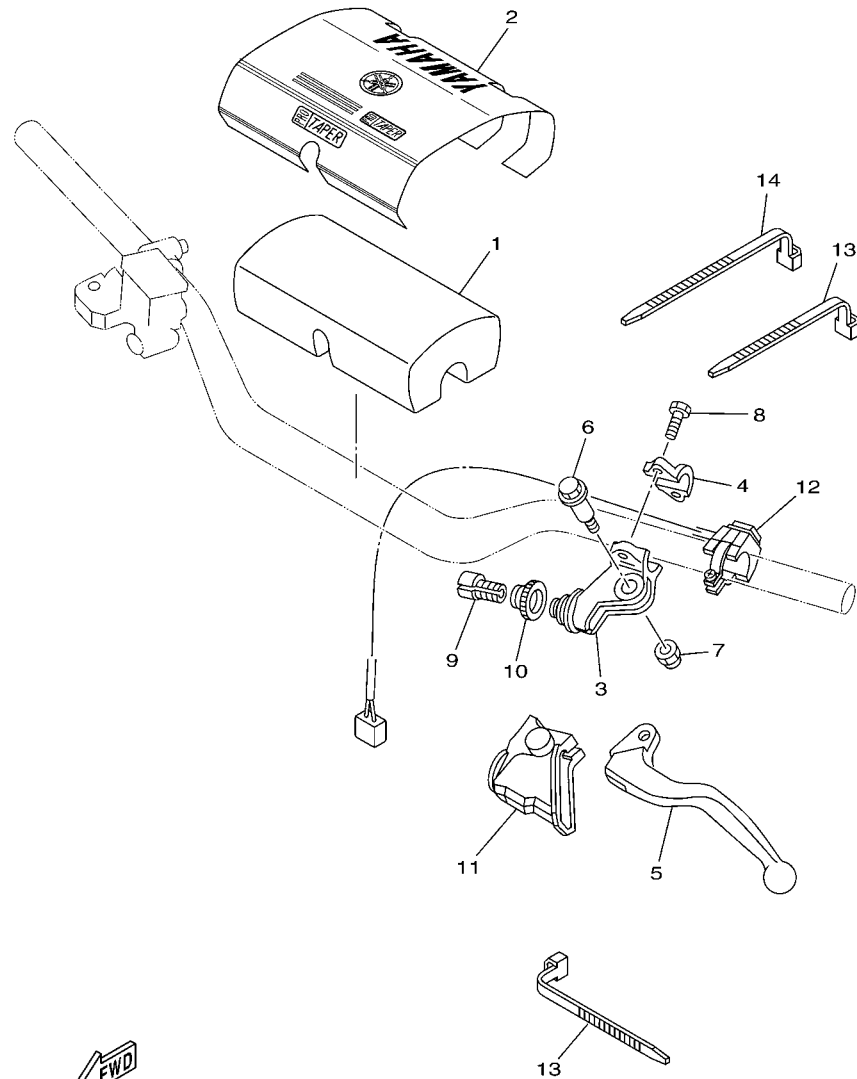

 1C39100-F340

FIG. 34 HANDLE SWITCH & LEVER

REF. NO.	PART NO.	DESCRIPTION	1P89	1P8A	1P8B	1P8C	REMARKS
1	5XC-26124-90	PROTECTOR, HANDLEBAR	1	1	1	1	
2	5XC-26143-90	COVER, HANDLEBAR UPPER 1	1	1	1	1	
3	5XE-82911-00	HOLDER, LEVER 1	1	1	1	1	
4	5TG-82913-00	HOLDER, LEVER LOWER 1	1	1	1	1	
5	5MV-83912-00	LEVER 1	1	1	1	1	
6	90109-06034	BOLT	1	1	1	1	
7	5LP-84126-10	NUT, LENS FITTING	1	1	1	1	
8	90101-05033	BOLT	2	2	2	2	
9	5HD-26337-00	BOLT, ADJUSTING	1	1	1	1	
10	5HD-83951-00	BOLT, CABLE ADJUSTING	1	1	1	1	
11	5HD-26372-00	COVER, HANDLE LEVER 1	1	1	1	1	
12	1C3-83976-00	SWITCH, HANDLE 1	1	1	1	1	
13	90464-13077	CLAMP	2	2	2	2	
14	90464-13073	CLAMP	1	1	1	1	

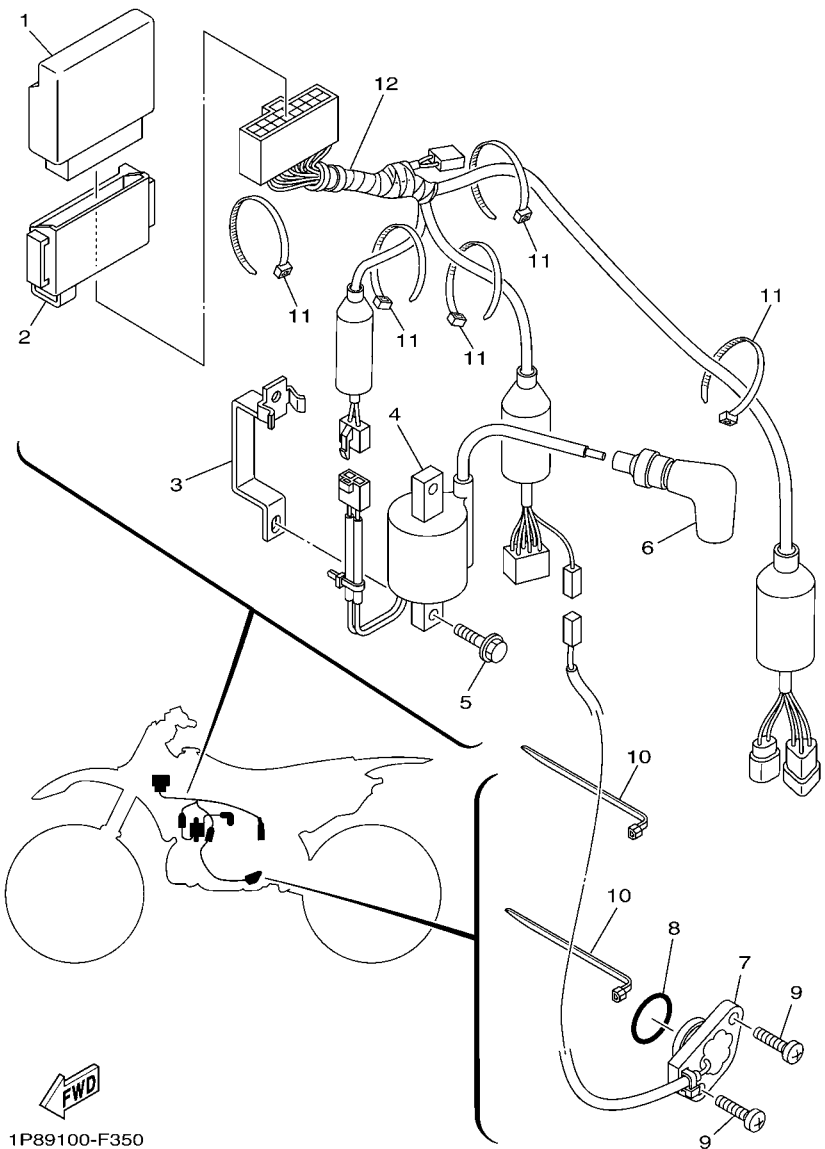
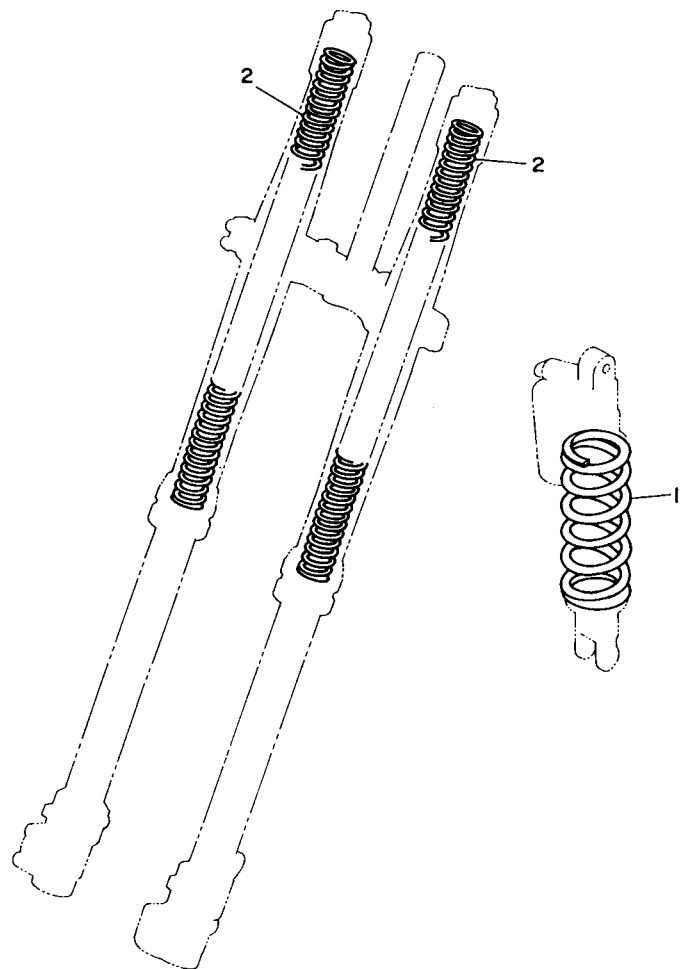

FIG. 35 ELECTRICAL 1

REF. NO.	PART NO.	DESCRIPTION	1P89	1P8A	1P8B	1P8C	REMARKS
1	1P8-85540-00	C.D.I. UNIT ASSY	1	1	1	1	
2	1P8-85546-00	BAND	1	1	1	1	
3	1P8-8231U-10	CORE, SIDE	1	1	1	1	
4	1P8-82310-00	IGNITION COIL ASSY	1	1	1	1	
5	90105-06060	BOLT, FLANGE	2	2	2	2	
6	8DG-82370-00	PLUG CAP ASSY	1	1	1	1	
7	1P8-82540-00	NEUTRAL SWITCH ASSY		1	1	1	
8	93210-21276	O-RING		1	1	1	
9	90154-05022	SCREW, BINDING		2	2	2	
10	90464-15195	CLAMP	2	2	2	2	
11	90465-13275	CLAMP	5	5	5	5	
12	1P8-82509-20	WIRE, SUB LEAD				1	

FIG. 36 ALTERNATE FOR CHASSIS



3JD1010-9360

REF. NO.	PART NO.	DESCRIPTION	1P89	1P8A	1P8B	1P8C	REMARKS
1	5UN-22212-00	SPRING (K=42N/MM)	1	1	1	1	AP
	1C3-22212-00	SPRING (K=44N/MM)	1	1	1	1	AP
	1C3-22212-10	SPRING (K=46N/MM)	1	1	1	1	AP
	1C3-22212-30	SPRING (K=50N/MM)	1	1	1	1	AP
	5UN-22212-50	SPRING (K=52N/MM)	1	1	1	1	AP
	5UN-22212-60	SPRING (K=54N/MM)	1	1	1	1	AP
	5UN-22212-70	SPRING (K=56N/MM)	1	1	1	1	AP
	5UN-22212-A0	SPRING (K=APPROX.44N/MM)	1	1	1	1	AP
	5UN-22212-B0	SPRING (K=APPROX.46N/MM)	1	1	1	1	AP
	5UN-22212-C0	SPRING (K=APPROX.48N/MM)	1	1	1	1	AP
	5UN-22212-D0	SPRING (K=APPROX.50N/MM)	1	1	1	1	AP
	5UN-22212-E0	SPRING (K=APPROX.52N/MM)	1	1	1	1	AP
	5UN-22212-F0	SPRING (K=APPROX.54N/MM)	1	1	1	1	AP
	5UN-22212-G0	SPRING (K=APPROX.56N/MM)	1	1	1	1	AP
2	1C3-23141-A0	SPRING, FRONT FORK(K=3.9N/MM)	2	2	2	2	AP
	1C3-23141-B0	SPRING, FRONT FORK(K=4.0N/MM)	2	2	2	2	AP
	1C3-23141-C0	SPRING, FRONT FORK(K=4.1N/MM)	2	2	2	2	AP
	1C3-23141-E0	SPRING, FRONT FORK(K=4.3N/MM)	2	2	2	2	AP
	1C3-23141-F0	SPRING, FRONT FORK(K=4.4N/MM)	2	2	2	2	AP
	1C3-23141-G0	SPRING, FRONT FORK(K=4.5N/MM)	2	2	2	2	AP
	1C3-23141-H0	SPRING, FRONT FORK(K=4.6N/MM)	2	2	2	2	AP
	1C3-23141-J0	SPRING, FRONT FORK(K=4.7N/MM)	2	2	2	2	AP

NUMERICAL INDEX

PART NO.	GRID NO.	PART NO.	GRID NO.	PART NO.	GRID NO.	PART NO.	GRID NO.	PART NO.	GRID NO.	PART NO.	GRID NO.
5UP-11111-00	B - 2	5MW-12422-00	B - 6	4XM-14451-00	B - 8	4MX-14948-09	B - 9	5CU-17131-01	C - 5	5XE-21610-10	C - 11
5MW-11111-01	B - 2	5XF-12428-00	B - 6	5NX-14453-00	B - 8	4MX-14948-10	B - 9	5BE-17141-30	C - 5	5XE-21635-10	C - 11
5UP-11311-10	B - 2	5DJ-12451-00	B - 6	5NY-14455-20	B - 8	4MX-14948-11	B - 9	5BE-17151-00	C - 5	1P8-2163G-00	C - 11
5XF-1131D-00	B - 2	5CU-12459-00	B - 6	3JD-14458-01	B - 8	4MX-14948-12	B - 9	5BE-17211-00	C - 5	5UN-21642-10	C - 11
5CU-1131E-01	B - 2	5NX-12461-00	B - 7	5NY-14459-00	B - 8	4JT-1494F-03	B - 11	5JT-17221-10	C - 5	3RV-21668-A0	C - 15
5CU-1131M-10	B - 3	22W-12462-00	B - 7	676-14548-00	B - 10	4JT-1494F-07	B - 11	5BE-17231-00	C - 5	3RV-21668-B0	C - 15
5CU-1131P-00	B - 2	1C3-12465-00	B - 7	4MX-14561-00	B - 9	4JT-1494F-09	B - 11	5JG-17241-00	C - 5	5NY-21711-00	C - 13
5CU-1131U-10	B - 2	5CU-12481-10	B - 7	5NX-14562-00	B - 11	4JT-1494F-11	B - 11	5BE-17251-10	C - 5	5GJ-21717-00	C - 9
5CU-1131V-00	B - 3	5NY-12482-00	B - 7	1P8-14610-00	B - 12	4JT-1494F-13	B - 11	5BE-17402-00	C - 5	5NY-21721-00	C - 13
5CU-1132A-00	B - 2	1P8-12484-00	B - 7	1P8-14610-10	B - 12	4JT-14984-00	B - 9	5BE-17411-00	C - 5	1C3-21721-50	C - 13
5MW-1132E-00	B - 3	353-13115-01	B - 3	3JE-14615-01	B - 12	4SR-14985-00	B - 9	5HC-17466-00	B - 15	5NL-2172A-20	C - 13
5MW-1132F-00	B - 3		B - 14	5MW-14642-00	B - 12	1P8-15111-00	B - 14	4L0-17471-00	B - 14	5XE-21730-00	C - 13
5UP-11351-00	B - 2	5NX-13565-00	B - 8	1P8-1469A-00	B - 12	5NX-15111-01	B - 14	5CU-18101-10	C - 8	1C3-2173E-20	C - 13
5CU-11354-00	B - 3	5NX-13610-10	B - 8	5HC-1469A-10	B - 12	4V4-15118-00	B - 14	1C3-18110-00	C - 8	1C3-2173F-20	C - 13
5NX-11395-00	B - 3	5NX-13613-00	B - 8	1P8-1469E-00	B - 12	5CU-15118-10	B - 14	5MW-18122-01	C - 8	5XE-21740-00	C - 13
5UP-11400-10	B - 5	4XL-13616-10	B - 8	1P8-14753-00	B - 12	5NX-15121-00	B - 14	4BR-18127-10	C - 7	1C3-22110-50	C - 14
5UP-11410-10	B - 5	5XF-13622-00	B - 8	5NX-14753-20	B - 12	3Y1-15363-00	B - 15	5CU-18140-01	C - 7	1C3-22111-00	C - 15
5MW-11420-10	B - 5	5NX-13624-00	B - 8	5CU-14771-01	B - 12	4JT-15381-01	B - 14	5CU-18172-00	C - 8	1C3-22122-00	C - 15
5CU-11603-10	B - 5	4XL-13625-00	B - 8	5XF-14781-00	B - 12	5CU-15411-10	B - 15	3XJ-18173-10	C - 8	1C3-22128-00	C - 14
	E - 10	1P8-14101-40	B - 9	4SR-14916-CJ	B - 9	5MW-15415-10	B - 15	3XJ-18178-00	C - 8	1C3-22141-10	C - 14
1P8-11630-00	E - 10	1P8-14101-50	B - 9	4SR-14916-CW	B - 9	1P8-15421-10	B - 15	3XJ-18182-00	C - 8	1C3-22151-00	C - 14
1P8-11631-00-A0	B - 5	1P8-14101-60	B - 9	4SR-14916-EH	B - 10	5NX-15431-00	B - 15	3XJ-18184-00	C - 8	5UN-22176-00	D - 2
1P8-11631-00-B0	B - 5	4SR-14105-00	B - 10	4SR-14916-EJ	B - 9	5CU-15451-00	B - 15	4EW-18185-00	C - 7	30X-22178-00	C - 9
	E - 10	4XL-1410E-00	B - 11	4SR-14916-EW	B - 9	5CU-15454-00	B - 14	5BE-18501-20	C - 7	3JD-22178-20	C - 9
1P8-11631-00-C0	B - 5	5NX-1410H-10	B - 11	4SR-14916-RH	B - 10	5CU-15462-00	B - 15	5BE-18502-20	C - 7	1C3-2217A-00	C - 14
1P8-11631-00-D0	B - 5	4MX-14115-00	B - 9	4SR-14916-RW	B - 10	5CU-15463-00	B - 15	5CU-18503-20	C - 7	1C3-2217F-50	C - 14
5UP-11633-00	B - 5	5HC-14126-00	B - 10	4MX-14919-00	B - 10	5NX-15601-10	C - 2	1P8-18541-00	C - 7	4V4-22184-00	C - 9
	E - 10	5HC-14131-00	B - 10	5HC-14922-00	B - 11	5NX-15620-20	C - 2	4UN-18542-00	C - 7	5MV-22184-00	D - 2
5MW-11650-00	E - 10	3TJ-14137-40	B - 10	5HC-14934-00	B - 11	5NX-15621-10	C - 2	5DH-18562-00	C - 7	1C3-22199-10	C - 14
5MW-11651-00	B - 5	4XL-14146-00	B - 9	4MX-14943-40	B - 10	5CU-15651-00	C - 2	1P8-21101-50	C - 9	1P8-22200-A0	D - 2
	E - 10	5HC-14146-00	B - 11	4MX-14943-41	B - 10	5NL-15664-00	C - 2	5PA-2118K-00	C - 11	1P8-22200-B0	D - 2
5CU-11681-00	B - 5	4JT-14147-00	B - 11	4MX-14943-42	B - 10	4GY-15671-00	C - 2	5PA-2118K-10	C - 11	1P8-22200-C0	D - 2
	E - 10	663-14159-00	B - 10	4MX-14943-43	B - 10	214-15674-00	C - 2	5PA-2118K-20	C - 11	1P8-22200-D0	D - 2
5CU-11830-00	B - 3	4JT-14171-00	B - 9	4MX-14943-44	B - 10	214-15686-00	C - 2	1C3-21190-90	C - 9	1P8-22200-E0	D - 2
4SS-11832-00	B - 3	4MX-14194-00	B - 11	4MX-14943-45	B - 11	5DJ-16111-00	C - 3	1C3-21244-10	C - 10	1P8-22201-A0	D - 2
5CU-11911-00	B - 4	4XL-14196-10	B - 10	4MX-14943-90	B - 10	5MW-16113-00	C - 3	1C3-21336-00	C - 9	1P8-22201-B0	D - 2
5CU-11912-00	B - 4	4XL-14197-10	B - 10	4MX-14943-91	B - 10	5DJ-16150-00	C - 3	1C3-2135F-00	C - 15	1C3-22212-00	E - 9
4JY-11915-10	B - 4	1P8-14208-00	B - 11	4MX-14943-92	B - 10	2K7-16154-00	C - 3	1C3-2139R-00	C - 15	5UN-22212-00	E - 9
5X4-11921-02	B - 4	5HC-14216-00	B - 11	4MX-14943-93	B - 10	5CU-16154-00	C - 3	5NX-21425-00	C - 9	1C3-22212-10	E - 9
3JE-11922-01	B - 4	5NX-14216-00	B - 11	4MX-14943-94	B - 10	2VM-16181-00	C - 3	1C3-21447-10	C - 9	1C3-22212-20	D - 2
5CU-11952-00	B - 4	5HC-14261-00	B - 10	4MX-14943-95	B - 11	3XK-16321-00	C - 3	1C3-21448-10	C - 9	1C3-22212-30	E - 9
5NY-11953-00	B - 4	5HC-14264-00	B - 11	4MX-14948-02	B - 9	4X7-16325-00	C - 3	1C3-21511-51	C - 11	5UN-22212-50	E - 9
5CU-11956-00	C - 3	5HC-14275-00	B - 11	4MX-14948-03	B - 9	5JG-16351-00	C - 3	4LB-2151H-02	C - 11	5UN-22212-60	E - 9
5CU-11990-10	B - 4	5HC-14340-A7	B - 10	4MX-14948-04	B - 9	4XL-16356-00	C - 3	3XJ-2151H-A1	C - 11	5UN-22212-70	E - 9
5CU-11991-00	B - 3	4MX-14392-00	B - 9	4MX-14948-05	B - 9	1P8-16357-00	C - 3	3XJ-2151H-B1	C - 12	5UN-22212-A0	E - 9
5CU-11993-00	B - 3	5NY-14401-01	B - 8	4MX-14948-06	B - 9	5NX-16371-00	C - 3	4XL-2153A-10	D - 7	5UN-22212-B0	E - 9
5CU-11995-00	B - 3	5NY-14417-00	B - 8	4MX-14948-07	B - 9	5CU-16380-10	C - 3	4ES-2153E-01	C - 11	5UN-22212-C0	E - 9
5NX-1240A-00	B - 7	5NY-14442-00	B - 8	4MX-14948-08	B - 9	5JG-17121-10	C - 5	5PA-21568-00	C - 11	5UN-22212-D0	E - 9

NUMERICAL INDEX

PART NO.	GRID NO.	PART NO.	GRID NO.	PART NO.	GRID NO.	PART NO.	GRID NO.	PART NO.	GRID NO.	PART NO.	GRID NO.
5UN-22212-E0	E - 9	1C3-2314F-M0	D - 5	1C3-2470F-50	D - 10	1C3-25876-50	E - 5	1P8-82509-10	E - 8	90105-06118	B - 7
5UN-22212-F0	E - 9	1C3-2314H-10	D - 7	5NY-24728-10	D - 10	1C3-25886-50	E - 5	1P8-82509-20	E - 8	90105-08085	C - 9
5UN-22212-G0	E - 9	1C3-2314J-10	D - 7	1C3-24770-51	D - 10	5MV-2589F-00	E - 3	1P8-82540-00	E - 8	90105-08131	C - 9
1C3-22213-L0	D - 2	5XE-23153-L0	D - 5	5NY-25104-00	D - 11	5UN-25914-00	D - 15	5XE-82911-00	E - 7	90105-08132	C - 9
1C3-22214-50	D - 2	2HH-23158-L0	D - 5	5NY-25111-00	D - 11	5DH-25914-50	D - 15	5TG-82913-00	E - 7	90105-08133	C - 9
5MV-22224-00	D - 2	1C3-2316A-N0	D - 5	5NY-25117-00	D - 11	3SP-25914-51	D - 12	5MV-83912-00	E - 7	90105-08134	D - 4
4JX-22226-00	D - 2	1P8-2316A-N0	D - 5	1C3-25181-10	D - 11	5DH-25916-00	D - 12	1C3-83922-50	E - 3		D - 7
3SP-22234-00	D - 2	1P8-23170-M0	D - 5	5NY-25183-00	D - 11		D - 15	5HD-83951-00	E - 7	90105-08136	B - 12
5NY-22241-00	D - 3	1C3-23170-R0	D - 5	5NY-25186-00	D - 11	3JD-25917-00	D - 12	1C3-83976-00	E - 7	90105-08137	D - 12
5XE-22242-00	D - 3	5XE-23171-L0	D - 5	5HD-25304-00	D - 13		D - 15	5LP-84126-10	E - 7	90105-10172	C - 9
1C3-22253-50	D - 2	5DH-23183-00	D - 2	5TJ-2530S-80	D - 14	5DH-25919-00	D - 12	1P8-85540-00	E - 8	90105-10173	C - 10
1C3-22253-L0	D - 2	509-23184-L0	D - 2	5ET-25311-00	D - 13	5DH-25919-50	D - 15	1P8-85546-00	E - 8	90105-10174	C - 10
4AA-22259-40	D - 2	1C3-23188-L0	D - 5	5ET-25317-00	D - 13	8CR-25924-00	D - 15	5UP-85550-01	E - 6	90105-10445	C - 3
4AA-22259-50	D - 2	1C3-23188-N0	D - 5	4XM-25364-00	D - 13	3SP-25926-51	D - 12	5CU-85560-20	E - 6	90109-05001	B - 2
4AA-22259-60	D - 2	1C3-23188-P0	D - 5	1C3-25381-90	D - 14	5DH-25933-00	D - 12	5NX-85885-10	B - 11	90109-05009	C - 3
4AA-22259-80	D - 2	1C3-23188-R0	D - 5	1C3-25388-50	D - 14	1UY-25937-51	D - 12	5NY-W0041-00	E - 3	90109-06034	E - 7
1P8-22355-00	C - 14	1C3-23190-L0	D - 5	1C3-25389-00	D - 14		D - 15	5UN-W0042-50	E - 5	90109-06198	C - 7
4EW-22474-00	D - 2	1P8-23340-M0	D - 7	3JE-25394-00	D - 13	1C3-26111-90	E - 2	5MV-W0045-01	D - 12	90109-067F4	B - 8
3JE-22475-00	D - 2	3SP-23356-L0	D - 7	5SF-25394-00	D - 11	5XC-26124-90	E - 7	1C3-W0046-10	D - 15	90109-08078	D - 13
5NY-22475-00	D - 2	5XE-23389-00	D - 7	1C3-25447-00	D - 13	5XC-26143-90	E - 7	3JD-W0047-00	D - 12	90110-08052	C - 2
1C3-22565-00	D - 2	4EW-23416-00	D - 4	1C3-25448-00	D - 13	4XM-26240-00	E - 2	5UN-W0047-50	D - 15	90111-06059	E - 5
5UN-22898-60	D - 15	1C3-23435-50	D - 4	1C3-25449-00	D - 13	4GY-26241-00	E - 2	1UY-W0048-50	D - 12	90116-08027	B - 2
1C3-22969-90	C - 14	5XC-23441-90	D - 4	1C3-25450-00	D - 13	4GY-26242-00	E - 2		D - 15	90116-10034	B - 2
1P8-23102-A0	D - 5	5XC-23442-90	D - 4	1C3-25451-00	D - 13	4XM-26243-00	E - 2	5UN-W0057-00	D - 12	90119-06133	B - 12
1P8-23102-B0	D - 5	1C3-23466-50	D - 12	1C3-25452-00	D - 13	1C3-26273-90	E - 2	5UN-W0057-50	D - 15	90119-06146	D - 4
1P8-23103-A0	D - 6	1C3-23467-50	D - 12	5CG-25715-00	E - 3	1C3-26281-90	E - 2	5XE-W2587-10	E - 3	90119-06147	C - 11
1P8-23103-B0	D - 6	1C3-23485-51	D - 4		E - 5	1C3-26282-90	E - 2	90101-05033	E - 7	90119-06149	C - 11
5XC-23110-L0	D - 6	1C3-24110-90	D - 8	1C3-25718-50	D - 15	4SS-26287-01	E - 2	90101-06041	C - 8	90119-08095	C - 13
1C3-23111-L1	D - 5	4EW-2412F-00	D - 8	1C3-2580T-00	D - 12	1C3-2628H-90	E - 2	90101-08006	D - 14	90122-06005	B - 8
276-23114-00	D - 5	5XE-24144-00	D - 8	1C3-2580W-60	D - 15	1P8-26311-90	E - 2	90105-05014	B - 4	90149-06074	B - 14
5XC-23120-L0	D - 5	3ME-2415E-01	C - 11	5MV-2581T-00	D - 12	1P8-26335-90	E - 2	90105-06060	E - 8	90149-06108	D - 8
5XE-23125-L0	D - 5	3XJ-2415E-A0	C - 11	5UN-25827-60	D - 15	5HD-26337-00	E - 7	90105-06064	C - 13		E - 6
1C3-23136-N0	D - 5	3XJ-2415E-B0	C - 11	5UN-25828-60	D - 15	1C3-26342-50	E - 2	90105-06081	C - 7	90149-06327	D - 12
1C3-23141-A0	E - 9	3XJ-2415E-C0	C - 11	5NY-2582W-00	D - 15	5HD-26372-00	E - 7	90105-06085	B - 14	90149-10031	C - 9
1C3-23141-B0	E - 9	4SR-2416E-00	C - 11	5MV-25833-00	E - 3	5NY-26372-00	E - 3	90105-06099	C - 11	90151-04003	C - 14
1C3-23141-C0	E - 9	3SP-24173-00	D - 8	1C3-2583V-00	E - 5	4XM-27200-10	E - 4	90105-06101	C - 11	90151-06045	C - 2
1C3-23141-E0	E - 9	5XE-24176-10	D - 8	5DH-25849-00	D - 12	5UN-27217-00	E - 5	90105-06103	C - 13	90154-05022	E - 8
1C3-23141-F0	E - 9	1C3-24181-00	D - 8	5MV-25852-01	E - 3	1C3-27217-10	E - 4	90105-06104	C - 14	90157-06008	B - 14
1C3-23141-G0	E - 9	1P8-24182-00	D - 8	5UN-25852-50	E - 5	5UN-27218-00	E - 5	90105-06105	C - 14	90159-06010	C - 3
1C3-23141-H0	E - 9	1C3-24183-00	D - 8	5XE-25853-00	E - 3	5UN-27222-00	E - 5		D - 12	90159-06021	C - 13
1C3-23141-J0	E - 9	1C3-24184-00	D - 9	5UN-25854-00	E - 5	1C3-27311-00	E - 4	90105-06107	D - 7	90170-20255	C - 3
1P8-23141-M1	D - 5	5NY-24186-00	D - 8	5XE-25854-00	E - 3	5XE-27411-01	E - 4		D - 8	90170-24003	D - 4
1C3-23142-L0	D - 5	1C3-24240-20	D - 8	5UN-2585B-00	E - 5	5XE-27421-01	E - 4		D - 15	90176-08005	B - 2
5XE-23144-L0	D - 5	3XJ-24380-00	D - 8	5MV-25867-00	E - 3	1C3-27491-50	D - 15	90105-06108	D - 15	90179-06028	C - 14
1C3-23145-M0	D - 5	3JD-24500-10	D - 8	5NY-25868-00	E - 3	5ET-28166-10	C - 10	90105-06110	D - 15	90179-08674	C - 10
5XE-23146-L0	D - 5	4X8-24512-00	D - 8	1C3-25872-90	E - 3	1P8-82310-00	E - 8	90105-06111	B - 7		D - 14
1AE-23147-00	D - 5	3AJ-24534-01	D - 8	1C3-25873-00	E - 5	1P8-8231U-10	E - 8		D - 15	90179-10658	C - 9
1C3-23147-L0	D - 5	5NY-24610-00	D - 8	1C3-25875-50	D - 12	8DG-82370-00	E - 8	90105-06112	E - 2	90179-10M35	B - 2

NUMERICAL INDEX

PART NO.	GRID NO.	PART NO.	GRID NO.	PART NO.	GRID NO.	PART NO.	GRID NO.	PART NO.	GRID NO.	PART NO.	GRID NO.
90179-12004	E - 6	90201-286K9	D - 4	90445-09777	B - 3	92012-06010	B - 12	93310-218A6	E - 10	95022-06025	B - 6
90179-16011	D - 11	90202-05193	D - 8	90445-111J0	D - 8	92502-06030	B - 15	93310-230T7	C - 3		B - 12
90179-20255	C - 6	90209-06096	B - 8	90450-25001	B - 7	92902-03100	B - 8	93310-52406	B - 5		B - 15
90179-28003	D - 4	90209-16011	C - 14	90450-28001	B - 7	92902-05600	B - 3		E - 10	95022-06030	B - 13
90183-06023	B - 8	90209-21332	C - 5	90450-51001	B - 8	92902-06100	D - 10	93315-11206	C - 3		B - 15
90185-08008	D - 13	90209-24327	B - 5	90450-70003	B - 8	92902-06600	B - 15	93315-32166	C - 14	95022-06050	B - 15
90185-08009	C - 9		E - 10	90462-08040	B - 14	92902-10200	C - 9	93317-22262	C - 14	95022-06065	B - 6
90185-10012	D - 3	90209-26348	C - 5	90462-08041	B - 14		D - 3	93332-00068	D - 4		B - 15
90185-14010	C - 15	90215-20231	C - 3	90464-06214	B - 8	92904-05600	C - 9	93332-00081	D - 7	95022-08040	C - 9
90185-16002	C - 14	90215-21256	C - 6	90464-13073	E - 7	93102-12106	B - 6	93340-21505	B - 4	95602-10200	D - 3
90185-20002	D - 14	90240-08120	E - 4	90464-13077	E - 7	93102-12224	C - 3		C - 3	95602-12200	D - 4
90201-03313	B - 8	90240-10004	E - 4	90464-15195	E - 8		C - 8	93342-22217	C - 14	95612-10660	B - 2
90201-05021	B - 2	90267-32070	B - 8	90465-13275	D - 8	93102-18278	C - 2	93410-20038	C - 2	95701-06500	E - 3
	B - 4	90280-03017	B - 5		E - 8	93102-20485	B - 5	93440-10085	C - 3	95702-06500	D - 12
90201-06013	C - 7	90340-12006	B - 14	90467-090A2	B - 7	93102-26468	D - 11	93440-25084	C - 5	97002-05020	B - 3
90201-06032	C - 11	90387-04003	E - 2	90467-100A1	D - 8	93102-28004	B - 5	93440-28062	C - 5	97002-06012	D - 10
90201-06033	B - 12	90387-06009	C - 11	90468-16001	E - 4	93102-32337	C - 5	93450-19052	B - 5	97004-05012	C - 9
	C - 11	90387-06039	B - 13	90480-08608	D - 14	93104-08040	B - 3		E - 10	97022-06016	C - 2
90201-06086	B - 13	90387-06065	B - 7	90480-15528	B - 7		B - 4	93507-16020	B - 4	97702-60016	C - 11
90201-06571	B - 7	90387-06090	C - 11	90480-16404	B - 13	93106-22002	C - 14	93507-32009	C - 2	98502-03008	B - 8
90201-08043	C - 9	90387-06104	D - 7	90480-16561	B - 12	93106-30001	D - 13	93603-14240	B - 4	98502-04012	B - 11
90201-08044	E - 4	90387-06121	B - 12	90480-17004	B - 12	93106-30045	D - 13	93604-08071	B - 2	98502-04014	B - 10
90201-08045	C - 9	90387-063G3	B - 12	90480-18549	D - 8	93109-11073	B - 6	93604-10011	B - 6	98502-05010	E - 5
90201-08048	C - 2	90387-08030	B - 12	90501-046L6	B - 3	93109-21001	C - 15	93604-29184	B - 4	98502-05012	B - 2
	D - 13	90387-08041	C - 9	90501-052G5	C - 8	93109-25001	C - 14	93612-16254	B - 14	98507-03008	D - 8
90201-08049	B - 12	90387-085E1	B - 4	90501-06022	C - 7	93109-28043	C - 14	9383E-13216	C - 6	98580-04006	B - 11
90201-08055	C - 10	90387-086N4	C - 9	90501-147A5	C - 2	93210-11073	E - 4	9383E-14215	C - 6	98680-04510	E - 2
90201-080L8	B - 2	90387-124F4	C - 8	90501-16016	C - 2	93210-15639	B - 2	94108-21012	D - 11	98680-04516	E - 2
90201-081G0	B - 3	90387-14005	C - 15	90501-237L0	C - 3	93210-17570	C - 2	94108-21015	D - 11	98702-06025	D - 8
90201-08512	B - 6	90387-152F2	B - 4	90501-256L2	B - 4	93210-19123	B - 15	94108-2112Y	D - 11	98706-04012	E - 3
90201-08784	B - 6	90387-16010	C - 14	90506-16007	E - 4	93210-21276	E - 8	94111-19011	D - 13	98902-05012	B - 3
90201-10032	E - 4	90387-18004	C - 14	90507-14064	C - 7	93210-22298	C - 5	94111-19015	D - 13		B - 4
90201-105P3	C - 3	90387-18007	B - 14	90507-20052	B - 12	93210-74316	B - 2	94111-1913A	D - 13	98902-05016	B - 3
90201-12028	D - 4	90387-18012	C - 14	90508-155B8	B - 3	93211-02703	B - 2	94209-21229	D - 11	98902-06025	D - 8
90201-12038	E - 6	90387-2113G	C - 5	90508-28015	E - 4	93300-60801	B - 4	94211-19273	D - 13	99001-06600	B - 6
90201-12575	C - 8	90387-227H7	E - 2	90508-28018	E - 4	93300-60839	C - 9	94211-19274	D - 13	99009-16400	C - 2
90201-125L6	C - 3	90387-2515B	C - 5	90508-291A8	C - 8	93306-00105	B - 6	94227-21101	D - 11	99009-20400	C - 2
90201-14020	C - 15	90401-10172	E - 3	90508-30743	C - 2	93306-00426	C - 5	94309-21161	D - 11	99009-45500	D - 13
90201-150U6	B - 4		E - 5	91312-04006	B - 4	93306-00442	C - 5	94311-19155	D - 13	99530-08016	B - 15
90201-16018	C - 14	90430-05242	C - 4	91312-04008	B - 3	93306-07202	D - 13	94321-19157	D - 13	99590-14016	B - 2
90201-162H4	C - 2	90430-06014	B - 6	91312-06012	B - 14	93306-20540	C - 5	94330-21084	D - 11	9Y581-92113	D - 14
90201-167P7	C - 2		B - 15	91312-06025	B - 8	93306-20574	C - 5	94416-21018	D - 11		
90201-20020	D - 14	90430-10005	E - 3	91312-06050	B - 14	93306-27212	D - 13	94421-19003	D - 13		
90201-20276	C - 2		E - 5	91312-06060	B - 14	93306-37808	B - 5	94681-68001	D - 14		
90201-20685	C - 2	90430-12227	B - 14	91312-06070	B - 14	93306-90409	D - 11	94702-00326	B - 2		
90201-21014	C - 14	90445-08376	B - 14	91402-20012	E - 4	93306-90501	C - 7	94709-00326	B - 2		
90201-24016	D - 4	90445-09220	D - 8	91402-25015	E - 4	93306-90506	C - 7	95022-06010	B - 15		
90201-253K0	C - 5	90445-09251	D - 8	91A20-05065	B - 7	93310-218A6	B - 5	95022-06020	C - 8		